

### INSTALLATION DESCRIPTION

The Series 3002xTJ32 is a 1500 pound holding force top jamb mounted electromagnetic lock designed to secure a double inswing door. The lock requires both installation procedures as described herein and in the separate wiring instructions included.

Typical installation of the lock on a double inswing door:

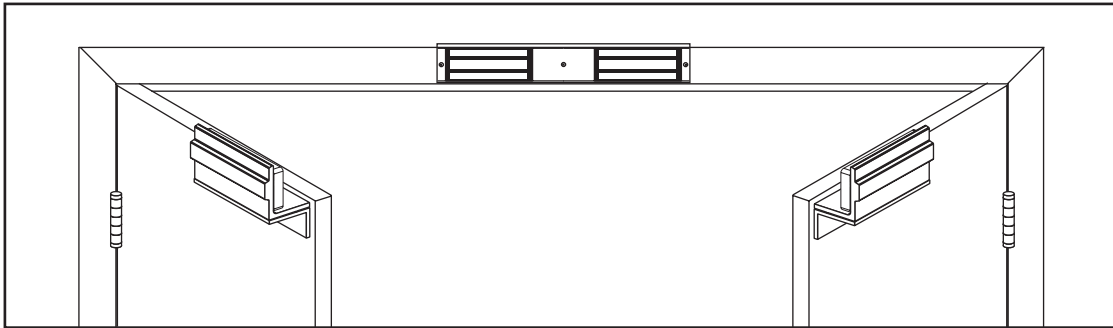

### HANDLING

Care must be taken that the lock face and armature face are kept free of dirt, rust, paint, or any other obstruction which may interfere with the lock and armature making good contact. These faces may be cleaned with a non-abrasive pad and wiped with an oil dampened cloth.

### MECHANICAL INSTALLATION

Familiarize yourself with the door and frame conditions. The lock must mount rigidly to the face of the door frame header. The door mounted armature is supplied with an adjustable mounting bracket and hardware that allows it to pivot slightly to compensate for reasonable misalignment.

**NOTE:** If this lock is supplied with the DSM option be certain that disc magnets are present inside the armature housing.

### ELECTRICAL INSTALLATION

After mechanical installation is complete the lock needs to be wired to a 12 or 24 VDC/VAC power source. Once low voltage power is supplied the unit is fully operational. All other wiring is for selected options. Refer to the separate wiring instructions included for further information.

### MOUNTING CONSIDERATIONS

1. Individual door and frame conditions may vary. Dimensions shown at right are for a typical hollow metal door and frame.
2. The lock assembly should be mounted at the center of the frame for maximum performance. Verify that there is proper clearance for the lock assembly at the planned mounting location.

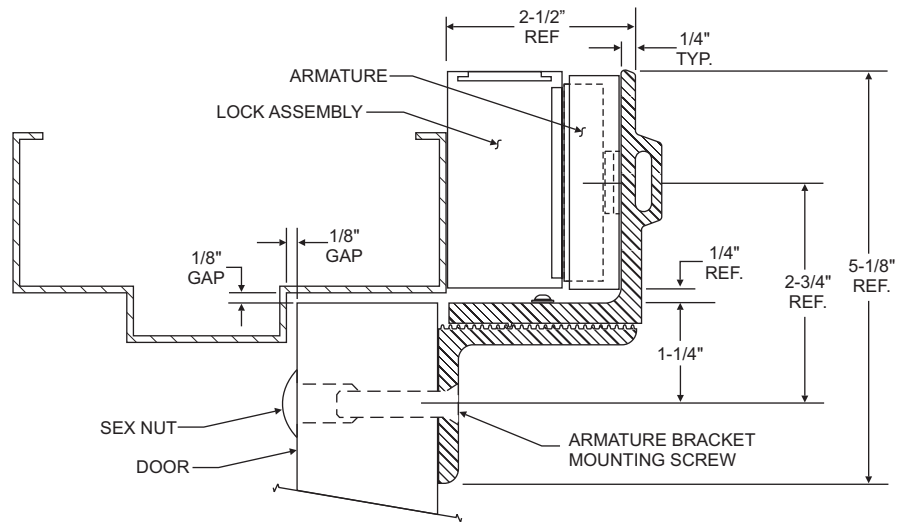

### INSTALL THE LOCK ASSEMBLY

1. Drill out the six dimpled mounting hole locations inside the back of the lock housing using a 3/16" drill. Position the lock assembly on the face of the frame header, on the pull side of the door as shown. Locate and mark the centers of the mounting holes.
2. Drill the marked holes in the face of the frame header:  
Six (6) 1/8" dia. mounting holes.
3. Attach the lock mounting bracket to the frame header using eight (8) #10 x 1" pan head Tek screws. Firmly tighten the screws using a #2 phillips screwdriver.

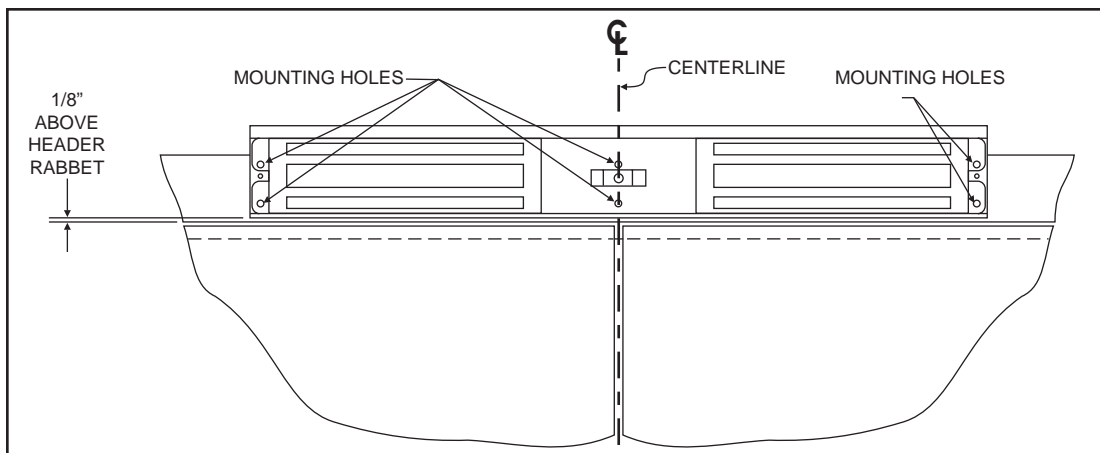
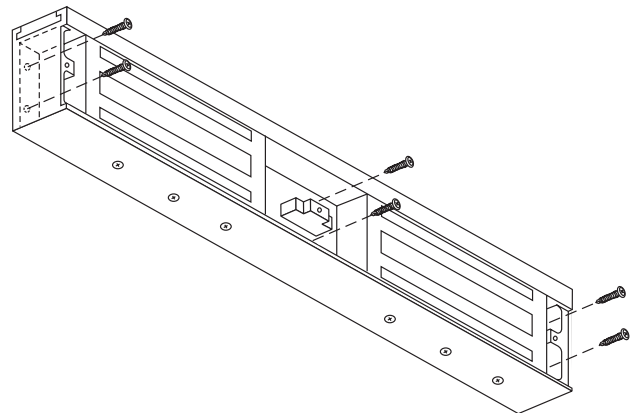

### ASSEMBLE THE ARMATURE MOUNTING BRACKET

Locate the two armature mounting bracket assembly screws and lock washers from the hardware kit and assemble the bracket as shown.

Firmly tighten the mounting screws with a 5/32" hex wrench. They may be loosened later for adjustment, as necessary.

Repeat process for second armature mounting bracket.

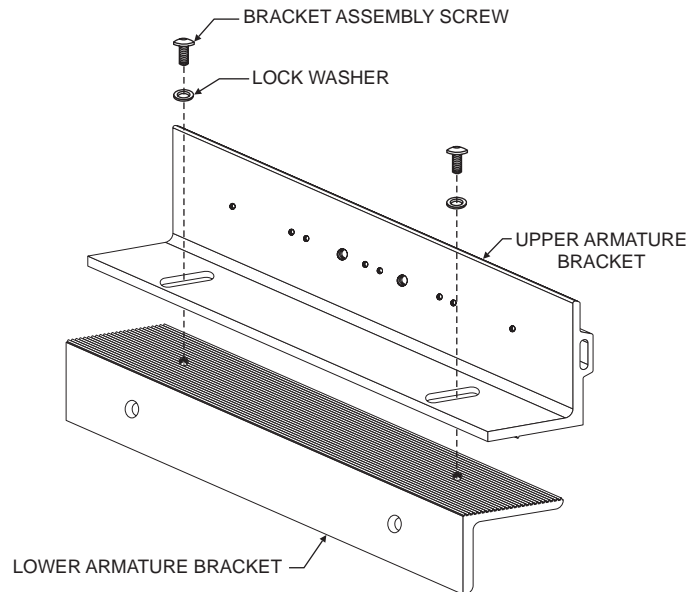

### ATTACH THE ARMATURE TO THE ARMATURE MOUNTING BRACKET

Attach the Armature Housing to the top Armature Mounting Bracket using four (4) 8-32x3/8" Armature Housing Screws.

Attach the armature to the armature mounting bracket as shown for LH door (Use alternate holes for RH door). Firmly tighten the Armature Mounting Screw using a 3/16" hex wrench.

**Failure to properly secure the armature to the bracket could result in serious injury or possible security breach.**

Repeat process for second armature mounting bracket.

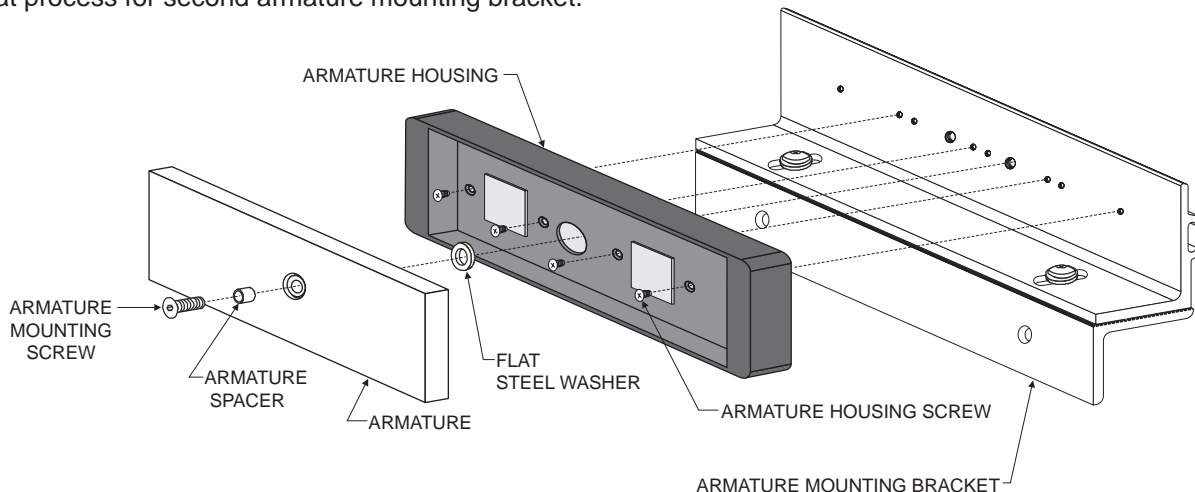

### INSTALL THE ARMATURE MOUNTING BRACKETS

1. Use the figure below to identify and mark the locations of the armature mounting bracket screw holes on each door leaf. Refer to door and frame prep drawing #301097 for further information.

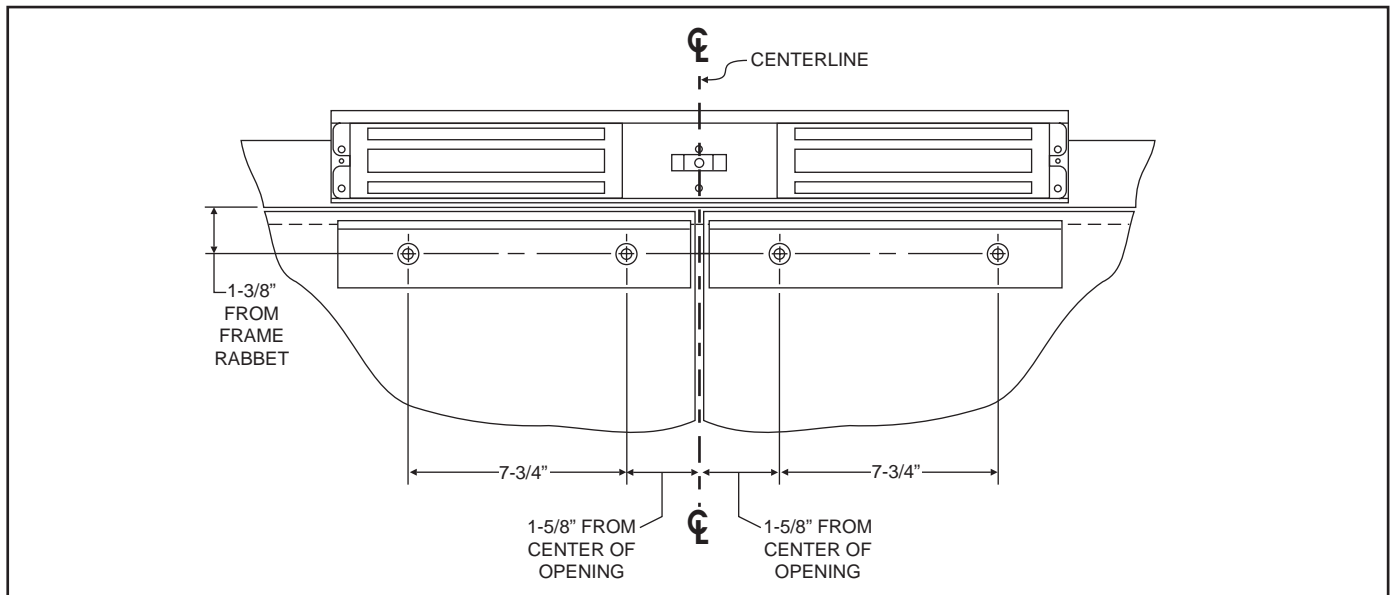

2. From the illustrations below select the one that resembles your door type and follow the instructions for drilling the two (2) armature mounting bracket screw holes.

#### GLASS & ALUMINUM OR HOLLOW METAL DOOR

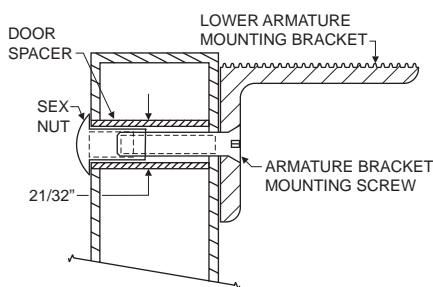

Drill an 11/32" diameter hole through door. From sex nut side only enlarge the 11/32" hole to 21/32" diameter.

#### SOLID CORE DOOR

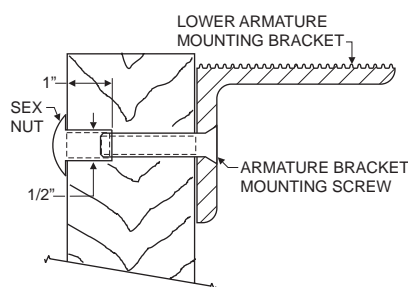

Drill an 11/32" diameter hole through door. From sex nut side only drill 1/2" diameter hole to 1" depth.

#### REINFORCED DOOR

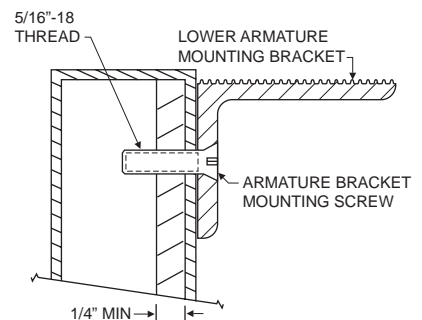

Drill an 11/64" diameter hole and tap for 5/16"-18 thread.

3. Mount the armature and mounting bracket assembly to the door using the appropriate hardware for you door type. Firmly tighten the mounting screws with a 3/16" hex wrench.
4. Repeat process for second armature mounting bracket.

### ARMATURE ADJUSTMENT

1. Using a 5/32" hex wrench, temporarily loosen the armature bracket assembly screws roughly 1-1/2 turns to allow the upper armature bracket to move in and out freely (Ref. Figure "A").
2. Close and latch the door. The mating surfaces of the lock and armature should fully contact each other. If necessary, slide the armature in or out to ensure full contact is made with the lock while still allowing the door to properly close and latch.
3. When the desired adjustment is achieved, slowly open the door taking care to maintain the position of the armature. Firmly tighten the armature bracket assembly screws, making sure that the locking ribs on the upper and lower bracket halves properly mesh (Ref. Figure "A")

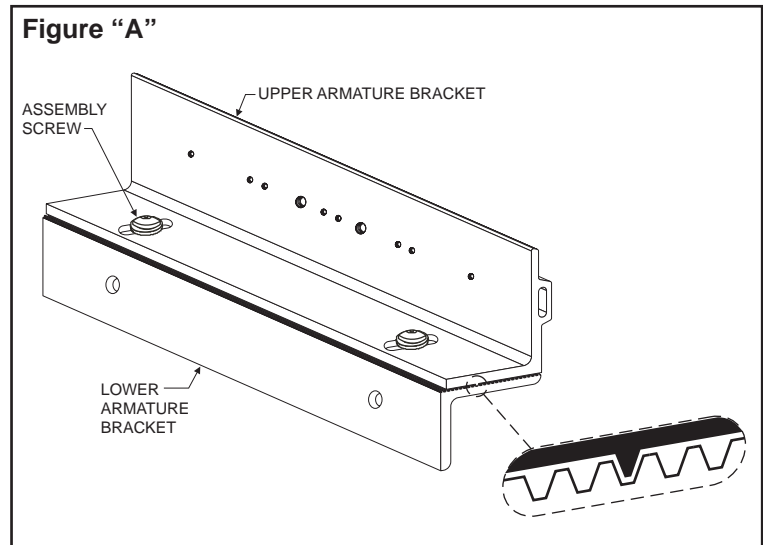

**NOTE:**

Make sure the door hits the frame just before the armature hits the maglock, to prevent loosening over time (armature not slamming against the lock).

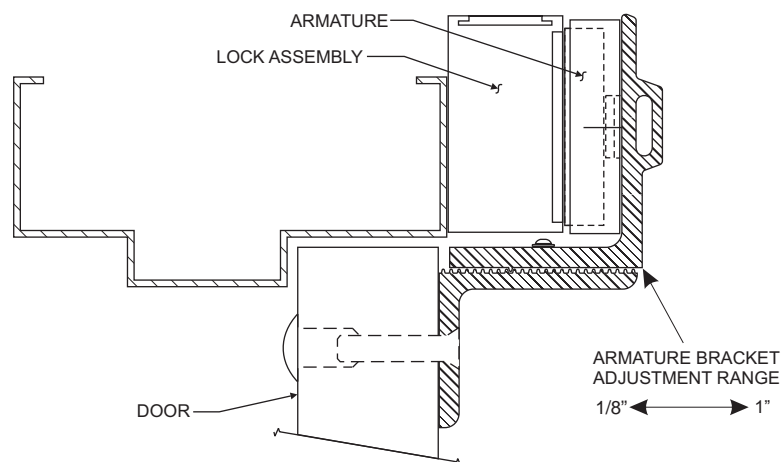



705 Emmett Street • Bristol, CT 06010  
 1-877-DynaLock • www.dynalock.com

**MODEL 3002xTJ32  
 ELECTROMAGNETIC LOCK  
 INSTALLATION INSTRUCTIONS**

**EXPLODED PARTS VIEW LEGEND**

ITEM	DESCRIPTION	PART #
1	Housing Assembly	300007
2	Armature	300013
3	Upper Armature Bracket	301254
4	Lower Armature Bracket	301260
5	Access Cover	300009
6	8-32x3/8" Machine Screw	300608
7	End Cover	300010
8	1/4-20x1/2" Button Head Screw	*
9	Lock Washer	*
10	#10x1" Self-Tapping Screw	*
10	10-24x1/2" Machine Screw	*

ITEM	DESCRIPTION	PART #
11	5/16-18x3/4" Arm. Screw, Turned	*
12	0.235"L Armature Spacer	*
14	Flat Steel Washer	*
15	Sex Nut	*
16	Door Spacer Tube	*
17	5/16-18x1-3/4" Bolt	*
18	Armature Housing	301244
19	8-32x3/8" Machine Screw	*
20	Disc Magnet (DSM & HSM only)	301289

\* Part of Hardware Kit (301315 x 2)

**Refer to Page 7 for parts locations.**

### EXPLODED PARTS VIEW

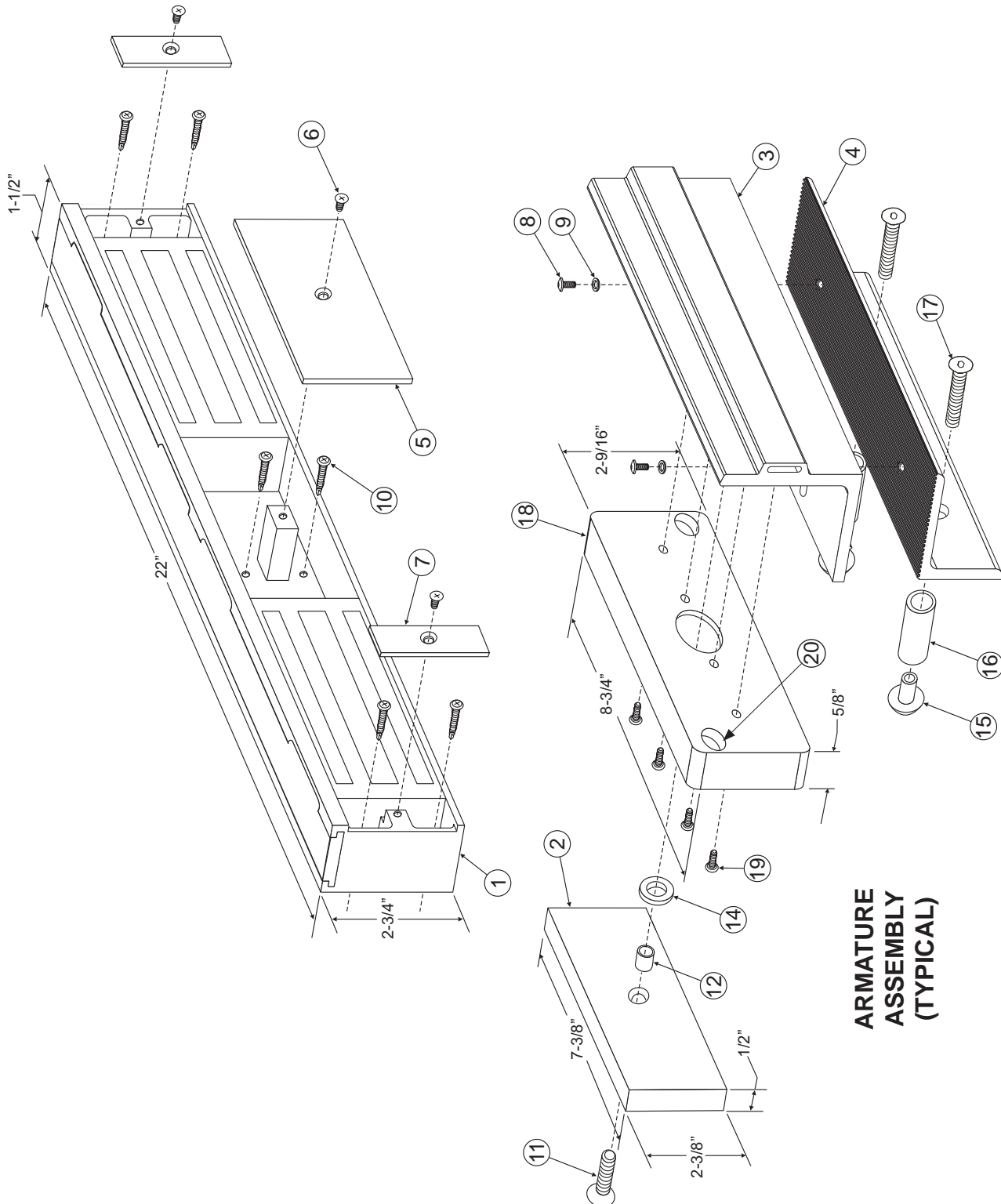

**ARMATURE  
ASSEMBLY  
(TYPICAL)**

Note: Refer to Page 6 for parts legend.



705 Emmett Street • Bristol, CT 06010  
1-877-DynaLock • www.dynalock.com

**MODEL 3002xTJ32  
ELECTROMAGNETIC LOCK  
INSTALLATION INSTRUCTIONS**

**PLEASE DELIVER THIS MANUAL  
TO THE END-USER UPON COMPLETION  
OF THE INSTALLATION**

**FOR PRODUCT SUPPORT AND PARTS  
ORDERING INFORMATION CONTACT:**

DynaLock Corp.  
705 Emmett Street  
Bristol, CT 06010  
Bus: (877) 396-2562 Toll-Free  
(860) 582-4761  
Fax: (860) 585-0338

**DYNALOCK ON THE INTERNET:**

E-mail: [info@dynalock.com](mailto:info@dynalock.com)  
Website: [www.dynalock.com](http://www.dynalock.com)



**NYC Mea #23-92-E  
GWXT Auxiliary Lock**