

ELECTRICAL DATA SHEET

THIS PRODUCT IS AN ELECTROMAGNETIC HOLDING DEVICE INTENDED FOR USE IN FIRE DOOR APPLICATIONS, BUT CAN BE USED FOR OTHER MAGNETIC APPLICATIONS. WIRE INTO PROPER TERMINALS AS NOTED BELOW:

PLEASE READ INSTRUCTIONS CAREFULLY!!

SERIES	VOLTAGE	DC/mA	DC/VA	AC/mA	AC/VA	TERMINALS
2801	12 DC	60	.72			Com & 12 v
	24 AC/DC	30	.72	30	.72	Com & 24 v
	120 AC			30	3.60	Com & 120 v

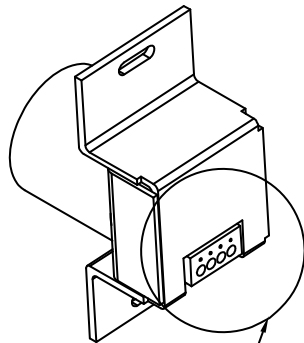

SEE WIRING DIAGRAMS TO THE RIGHT FOR YOUR APPLICATION

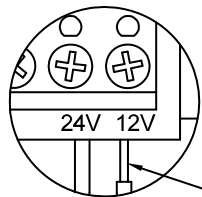

CAUTION
DO NOT LEAVE
WIRE EXPOSED

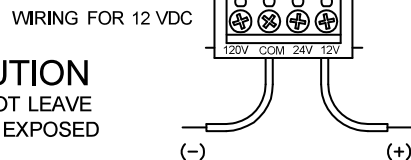
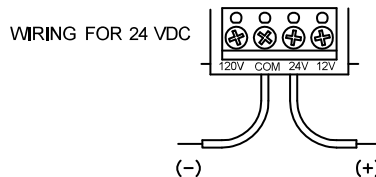
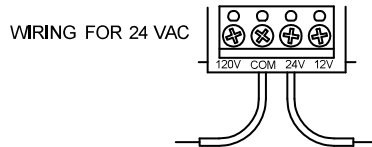
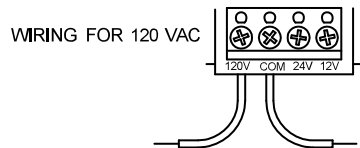

ELECTROMAGNETIC DOOR HOLDER ASSEMBLY INSTRUCTIONS & ELECTRICAL CONFIGURATIONS

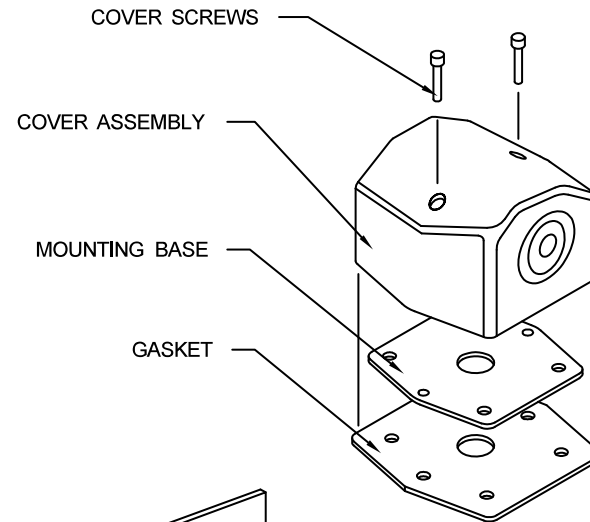

ILLUSTRATION 1-1

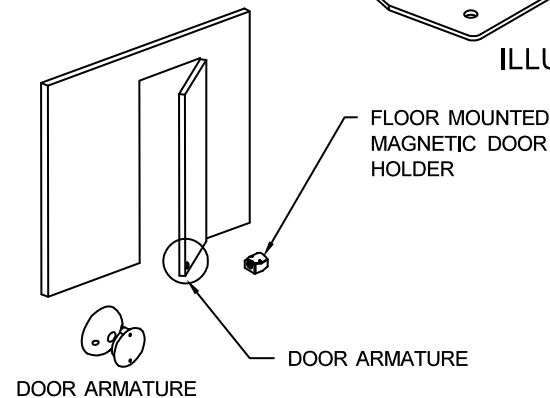

ILLUSTRATION 1-2



DynaLock Corporation
705 Emmett Street
Bristol, CT 06010
Ph/ 860.582.4761
Fx/ 860.585.0338
E-mail/ info@dynamlock.com

WWW.DYNALOCK.COM

© 2010 DYNALOCK CORP. Printed in USA

Electromagnetic Door Holder Model 2801

Step #1 Locations of Magnet Box:

1-1 Find the following:

1. Pivot point of door
2. Door Width (Inches)
3. Maximum degree of door opening permitted by door opener.
(Note trim and partition clearance needed)

1-2 Determine arc length by subtracting 5 5/8" from width of door.

Example: If door is 36"

Width of door 36"

Subtract 5 5/8"

Arc Length = 30 3/8"

1-3 Determine degree of desired door opening with consideration for partition

Allow 6" Dia clearance around conduit and any partition for 2600 Series assembly
(See drawing below)

(Conduit should be located on an arc and 4 1/8" from the pull side of door, when the door is at the maximum degree of door opening)

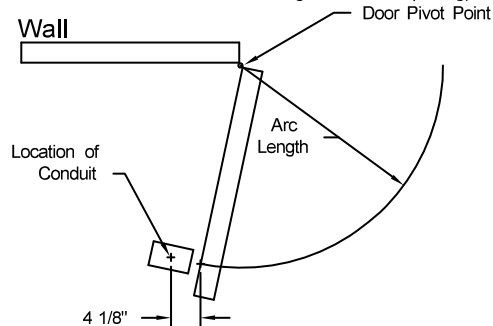

Step #2 Installation of Wall Magnet Box:

2-1 Locate magnet assembly on pull side of door near bottom rail

Approximately 6" from lock edge using floor mounting base as template. See illustration below.

2-2 Using the marked locations, drill mounting holes in floor for 5/8" floor anchors.

2-3 Mount magnet base to floor using 5/8" anchors and screws.

2-4 For detail on electrical wiring, read the specific "Electrical Data Sheet" at the end of this documentation.

IMPORTANT: Check that power voltage equals voltage labeled on back of magnet

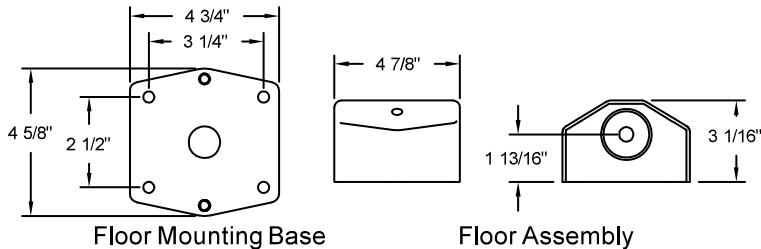

Step #2 Continued:

2-5 Position cover gasket on base.

2-6 Assemble cover to base plate using provided mounting screws.

Step #3 Installation of door armature hardware:

3-1 With the magnet box securely fastened, aligned and energized, place and center the door armature on the surface of the magnet with the two holes of the base aligned either vertically or horizontally.

3-2 Gently close the door and adjust the angle of the door armature so the base lays flat against the door.

3-3 While keeping slight pressure on the door, mark location of door armature through the two base holes. The two marks should be 1 3/4" apart and the center line of the door armature should be approximately 6" from the lock edge of the door.

3-4 Depending of the mounting option that you choose:

For concealed Mounting

Drill a 1/2" deep hole where the two marks are located with a 1/16" maximum diameter drill as pilot holes for wood screws. In reinforced metal door, drill & tap for #10-32 screw

OR:

For through bolt Mounting

Drill through the door where the two marks are located with a 5/16" drill.

3-5 Mount the door armature on the door:

For concealed Mounting

Use two #10 pan head phillips wood screws or two #10-32 screws depending on type of door (See step 3-4)

OR:

For through bolt Mounting

Use two #10-32 screws with two #10-32 x 1 1/4" sex bolt.

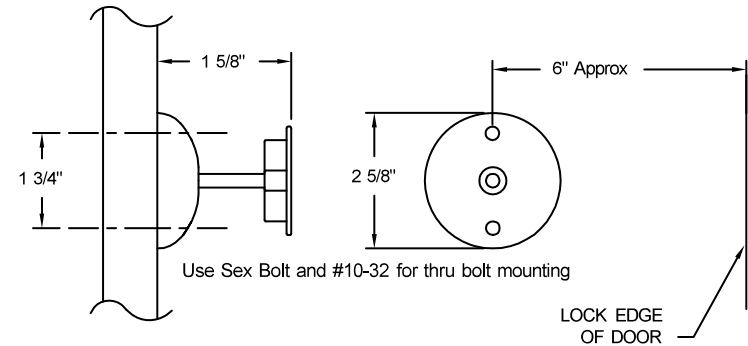

DynaLock Corporation
705 Emmett Street
Bristol, CT 06010
Ph/ 860.582.4761
Fx/ 860.585.0338
E-mail/ info@dynalock.com

WWW.DYNALOCK.COM

© 2010 DYNALOCK CORP. Printed in USA

Electromagnetic Door Holder Model 2801

M2801IN-01 06/2010 Page 2 of 2