

Description

The 2801 Series is a floor mount door holder for use with single doors. The 2802 Series is a floor mount door holder for double doors. All are UL and cUL Listed and FM approved.

Table 1. Specifications

Cat. No.	Voltage	Current Draw
2801	24V AC 60 Hz	0.015A
	24VDC	0.015A
	120V AC 60 Hz	0.015A
2802	24V AC 60 Hz	0.030A
	24VDC	0.030A
	120V AC 60 Hz	0.030A

Installation

Conduit Location

Install and wire in accordance with applicable codes, standards, such as NFPA publications 70 (National Electrical Code), 72 (National Fire Alarm Code) and 80 (Standard for Fire Doors and Fire Windows) and authorities having jurisdiction

1. Measure the door width. Calculate the radius (Figures 1 and 2) by subtracting 5-5/8" from the door width.
2. **Single Door (Figure 1):** Using the radius calculated in step 1, draw an arc (using the pivot point of the door as the center point) through the desired location of the door opening. Open the door and draw a line through the arc 4-1/8" from the pull side of the door.

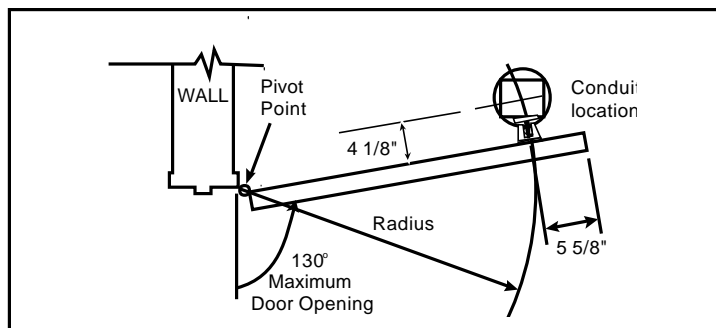

Figure 1. Single Door Conduit Location

NOTE: A 6" center clearance is required around the conduit center for the door holder assembly.

3. **Double Door (Figure 2):** Using the radius calculated in step 1, draw an arc (using the pivot point of each door as the center point) through the desired location of the door opening. Locate the conduit where the two arcs intersect.

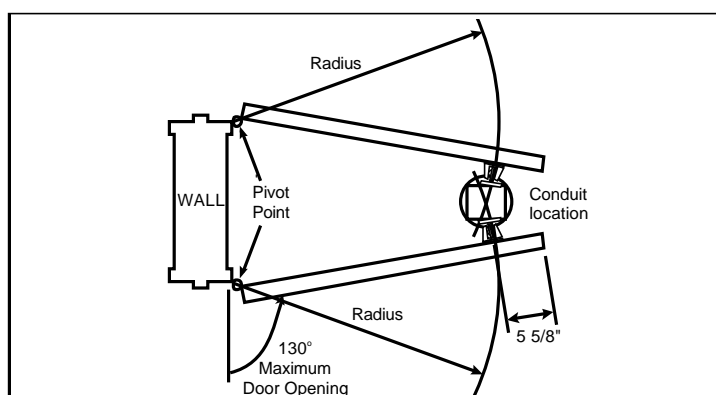

Figure 2. Double Door Conduit Location

4. Install conduit.

NOTE: Maximum height of threaded conduit is 3/4" above floor line. Maximum conduit size is 1/2". Position the base plate so that the magnet lines up with the contact plate on the door.

Floor Plate and Gasket Mounting

1. Position the mounting base plate as a template and mark the four through holes. Remove the plate and drill holes 3/8" x 1-5/8" deep in the floor. See Figure 3.
2. Install the cement anchors in the mounting holes. Remove the cap from the conduit. Position the gasket and base plate on the floor over the conduit.
3. Place the gasket on the floor. Set the plate over the gasket with the extruded bosses facing away from the gasket and secure using (4) #1/4-20 x 1" screws (supplied). Install the conduit nut on top of the plate.

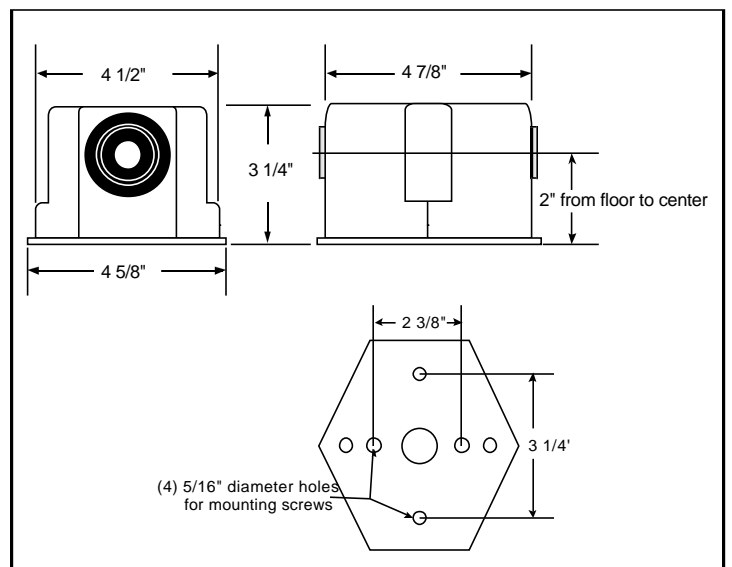

Figure 3. Dimensions

WARNING
 To prevent electrical shock, ensure power is disconnected.

Electromagnetic Assembly Mounting

1. Pull field wiring through conduit.
2. Establish earth-ground continuity in accordance with applicable codes, standards and authorities having jurisdiction.
3. Refer to Figure 4 and connect as instructed below:
 - a. **120V AC operation.** Connect field wiring to terminals marked "120V AC" and "COM".
 - b. **24V AC/DC operation.** Connect field wiring to terminals marked "24V AC/DC" and "COM".
 - c. For double door models connect the corresponding terminals from both electromagnet terminal blocks in parallel to input power field wiring.
4. Mount the connected assembly onto the floor plate and secure it using (2) #1/4-20 x 1" screws (supplied).

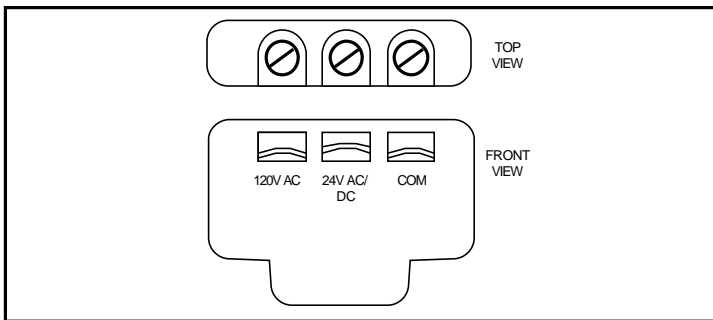

Figure 4. Terminal Block

Armature Assembly Mounting

NOTE: Armature assembly must be mounted vertically (Figure 5) to obtain correct alignment with the electromagnet.

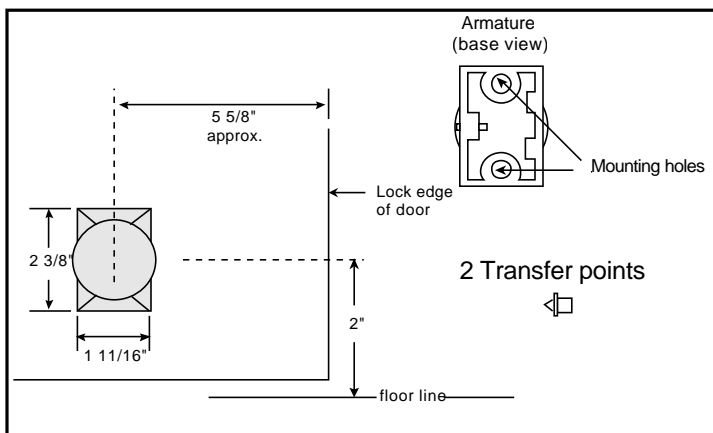

Figure 5. Armature Mounting

- Using a 5/32" Allen wrench, turn the contact plate adjusting screw (Figures 6 and 7) counterclockwise to loosen the contact plate.
- Place the transfer marking points in the armature mounting holes (Figure 5).

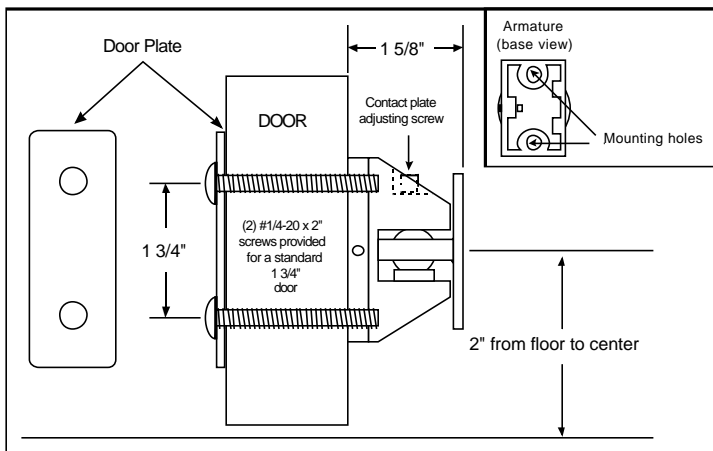

Figure 6. Thru-Bolt Mounting

- To locate the two mounting holes in the door, hold the contact plate centered against the magnet, open the door and press against the transfer marking points on the armature base.

- Mount the armature assembly using one of the following methods:
 - Thru-bolt mounting (Figure 6).** Center punch the two holes (at the points marked in step 3) and drill 5/16" diameter through the door. Distance between the center points should equal 1-3/4".

NOTES: Thru-bolt mounting is recommended for standard 1 3/4" hollow metal, hollow core or composite type wood doors. For 2" doors use (2) 1/4-20 x 2" bolts.

Secure the armature assembly, with the contact plate adjusting screw facing up, to the door as shown in Figure 6 or 7 using (2) #1/4-20 x 2" screws (supplied).

- Surface concealed mounting (Figure 7).** Measure two points for 1/8" holes drilled 1/2" on center, equidistant from each marked point. Center punch the holes and drill 1/8" diameter x 1-1/4" deep. Install the concealed mounting plate using two #10 x 1-1/2" screws provided.

NOTE: Surface concealed mounting is not recommended for hollow metal, hollow core or composite type wood doors.

Align the holes for the concealed mounting plate in the armature base with the pins on the concealed mounting plate and secure the armature assembly to the door by tightening the set screw.

- Align the contact plate against the electromagnet. The contact plate **must be** centered and lie flat against the magnet to ensure sufficient holding force. Tighten the contact plate adjusting screw until the plate is firm but not set. **Do not overtighten the contact plate.**
- Recheck alignment and adjust if necessary.
- Adjust the door closer to exert 3 pounds of force when the door is open and armature and magnet are in contact.
- Energize the electromagnet and check operation.

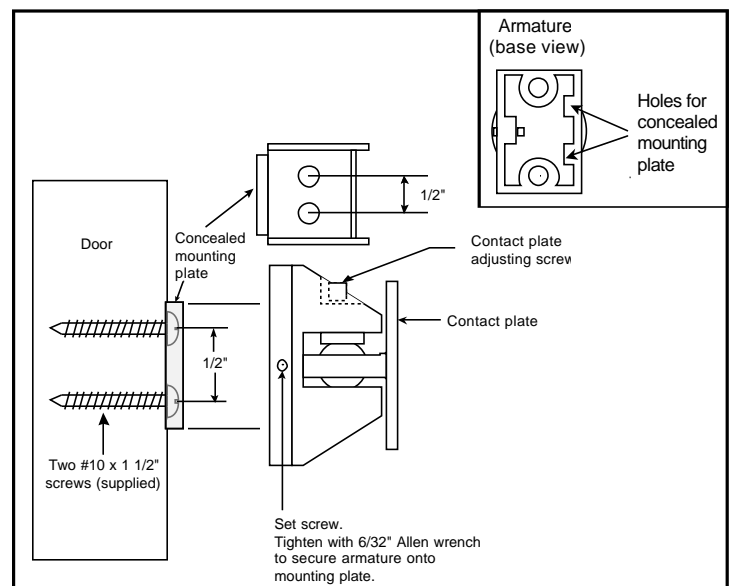

Figure 7. Surface Concealed Mounting