

INSTALLATION DESCRIPTION

The Series 2280 is a 1200 pound holding force electromagnetic lock designed to secure a single outswinging door. The lock requires installation procedures as described herein and in the separate wiring instructions included.

Typical installation of the lock on a RHR single outswinging door:

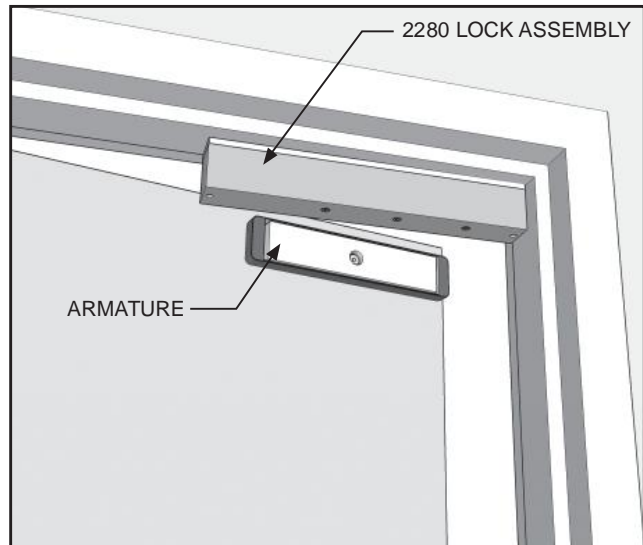

HANDLING

Care must be taken that the lock face and armature face are kept free of dirt, rust, paint, or any other obstruction which may interfere with the lock and armature making good contact. These faces may be cleaned with a non-abrasive pad and wiped with an oil dampened cloth.

MECHANICAL INSTALLATION

Familiarize yourself with the door and frame conditions. The lock must mount rigidly to the under side of the door frame header. The door mounted armature is supplied with hardware that allows it to pivot slightly to compensate for reasonable misalignment.

NOTE: If this lock is supplied with the DSM option be certain that magnets are present inside the armature housing.

ELECTRICAL INSTALLATION

After mechanical installation is complete the lock needs to be wired to a 12 or 24 VDC/VAC power source. Once low voltage power is supplied the unit is fully operational. All other wiring is for selected options. Refer to the separate wiring instructions included for further information.

TABLE OF CONTENTS

General Information.....	1
Bill Of Materials.....	2
Mounting Considerations.....	3
Using The Template.....	3
Mounting The Armature.....	4
Mounting The Lock.....	5
Exploded Parts View.....	6
Exploded Parts Legend.....	7
Support.....	8

MODEL #2280 BILL OF MATERIALS

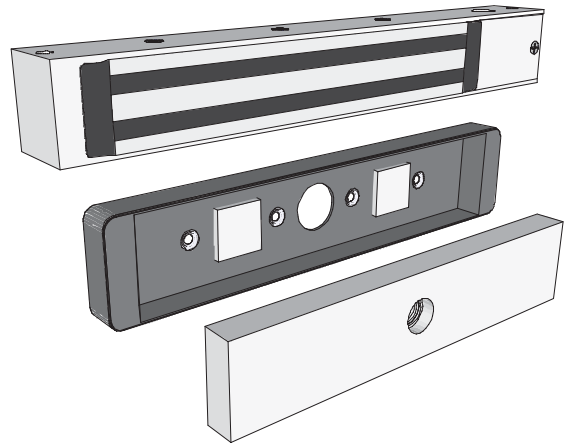

- (1) 2280 LOCK ASSEMBLY
- (1) ARMATURE
- (1) ARMATURE HOUSING
- (1) HARDWARE KIT
- (1) MOUNTING TEMPLATE
- (1) INSTALLATION MANUAL
- (1) WIRING MANUAL

REQUIRED TOOLS

- (1) Electric Drill
- (1) #2 Phillips Screw Driver
- (1) Soft Faced Mallet
- (1) Hammer
- (1) Center Punch
- (1) Pencil & Tape

Drill Bits: 1/8", 17/64", 11/32", 1/2", 9/16", 21/32"

HARDWARE KIT CONTENTS (P/N 301304)

QTY.	ITEM	DESCRIPTION
7	Baseplate Mounting Screws	#10x1" phillips pan head sheet metal screw
7	Baseplate Mounting Screws	#10-24x1/2" phillips pan head machine screw
1	Armature Mounting Screw	5/16-18x2" hex flat head machine screw, turned
4	Armature Housing Screws	#8x1" phillips flat head sheet metal screw
4	Armature Housing Screws	8-32x3/8" phillips flat head machine screw
1	Armature Spacer	3/8"Dx0.360"L spacer
1	Steel Washer	1/4" flat steel washer
1	Door Spacer	5/8"Dx1-11/16"L spacer
1	Sex Nut	5/16-18 sex nut
2	Anti-Tamper Plug	
1	3/16" Hex Wrench	

NOTE: For further parts clarification refer to the Exploded Parts View on page 6 or consult factory.

MOUNTING CONSIDERATIONS

Inspect the door frame and determine if an angle bracket, filler or spacer plate will be required for installation.

Note: Remember to leave space so that the door hits the stop *before* the maglock, to prevent loosening over time.

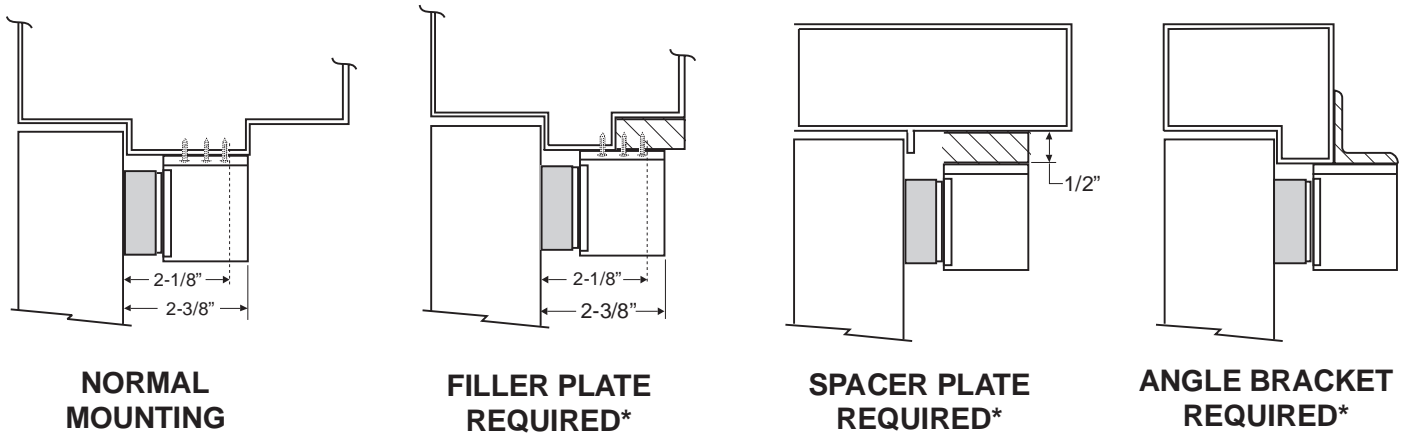

**NORMAL
MOUNTING**

**FILLER PLATE
REQUIRED***

**SPACER PLATE
REQUIRED***

**ANGLE BRACKET
REQUIRED***

*See Price Book or visit www.dynalock.com - 4000 Series Mounting Accessories

USING THE TEMPLATE

1. Fold the template on the dotted line to form a 90 degree angle. Scoring the template with a straight edge and a screwdriver will make it fold easier.
2. With the door in the closed and latched position, from the push side, place the template against the header and door with one edge against the vertical strike jamb and tape in place.
3. Transfer all hole locations to both the door and header with a center punch, then remove the template from the door.
4. Referring to the template drill two 1/8" dia. lock mounting holes (or tap for 10-24) and one 9/16" dia. wiring hole in the top of the frame, at the transferred locations. Remaining mounting holes will be drilled after lock is first mounted and adjusted (page 5).
5. Drill the remaining transferred holes in the face of the door to accept the Armature, following the instructions on page 4 for your specific door type.

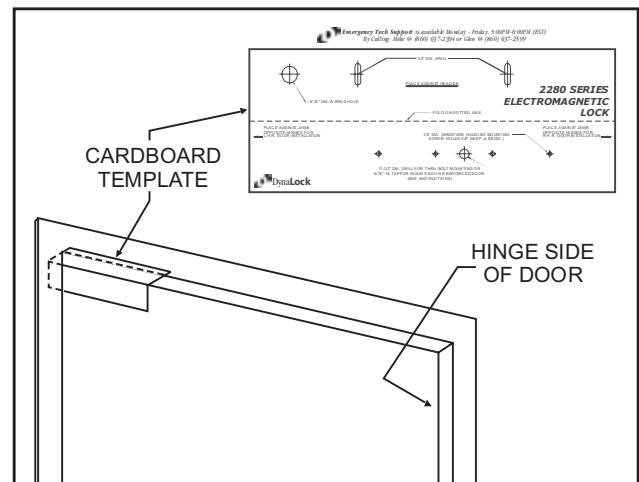

MOUNTING THE ARMATURE

From the three illustrations below, select the one that resembles your door type and follow the instructions for drilling the Armature Mounting Screw hole. (See Template)

Drill four (4) 1/8" dia. holes for #8 x 1" sheet metal screws or drill and tap for #8-32 x 3/8" machine screws (See Template).

GLASS AND ALUMINUM OR HOLLOW METAL DOOR

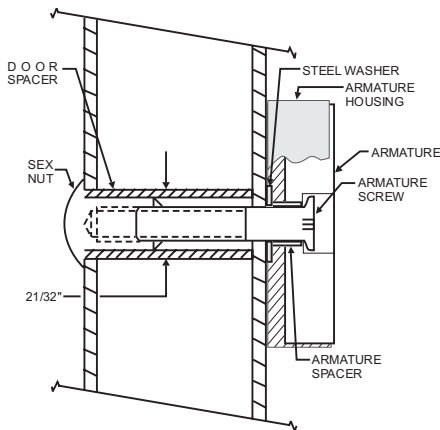

Drill an 11/32" diameter hole through the door. From the sex nut side only enlarge the hole to 21/32" diameter.

SOLID CORE DOOR

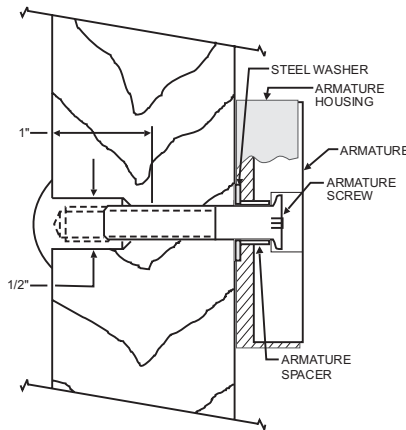

Drill an 11/32" diameter hole through the door. From the sex nut side drill 1/2" diameter hole to 1" depth.

REINFORCED DOOR

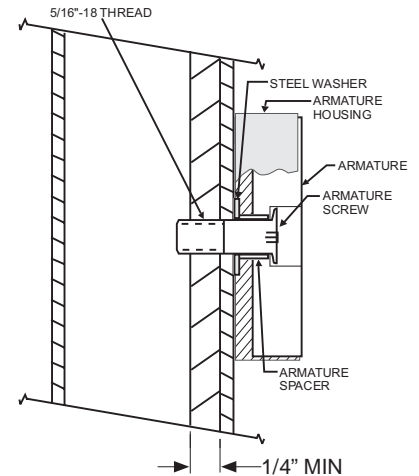

Drill a 17/64" diameter hole and tap for 5/16-18 thread

Mount the Armature Housing to the door using four (4) #8 x 1" sheet metal screws or #8-32 x 3/8" machine screws.

Place the Armature inside the Armature Housing and secure using the proper hardware, according to the above illustrations. Firmly tighten the Armature mounting screw with a 3/16" hex wrench.

Failure to properly secure the Armature to the door could result in serious injury or possible security breach.

MOUNTING THE LOCK

1. **Mount the Baseplate to the header.** Separate the baseplate from the lock housing with a 3/16" Hex wrench. Place the Baseplate against the header with the counter sunk slots visible, and the large slot over the wire hole. Attach the baseplate to the header at both slotted locations using the holes drilled on page 3. Tighten the screws just snug enough to allow for final adjustment.

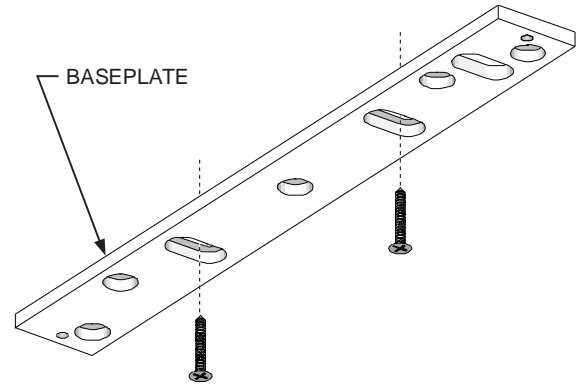

2. **Align the Lock and Armature.** Close and latch the door. Temporarily mount the lock to the baseplate and verify:

- the lock face and armature are making full contact for the entire length of the armature
- the armature is horizontally centered on the lock face
- the door hits the frame just before the maglock (not slamming on the lock)

If any adjustment is required, gently tap the baseplate with a soft mallet until full contact is achieved. Mark two baseplate corner locations lightly with a pencil for reference. Remove the lock from baseplate and tighten both adjustment screws. Drive the remaining 5 screws into the header using the baseplate as a physical template. Screw heads must not project above the baseplate.

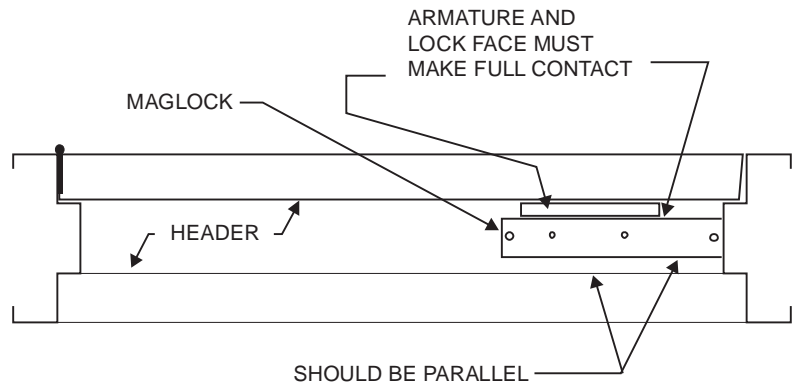

3. **Attach the Lock to the Baseplate.** With the 3/16" Hex wrench, permanently fasten the lock to the Baseplate with the two 1/4"-20 x 1-1/4" machine screws removed earlier.

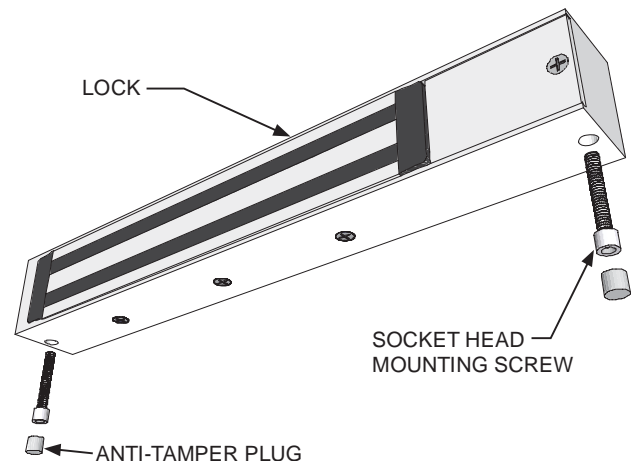

4. **Install the tamper plugs.** Gently tap the two Anti-Tamper Plugs into the Mounting Screw Holes using a soft faced mallet.

5. **Complete Wiring.** See separate wiring instructions.

EXPLODED PARTS VIEW

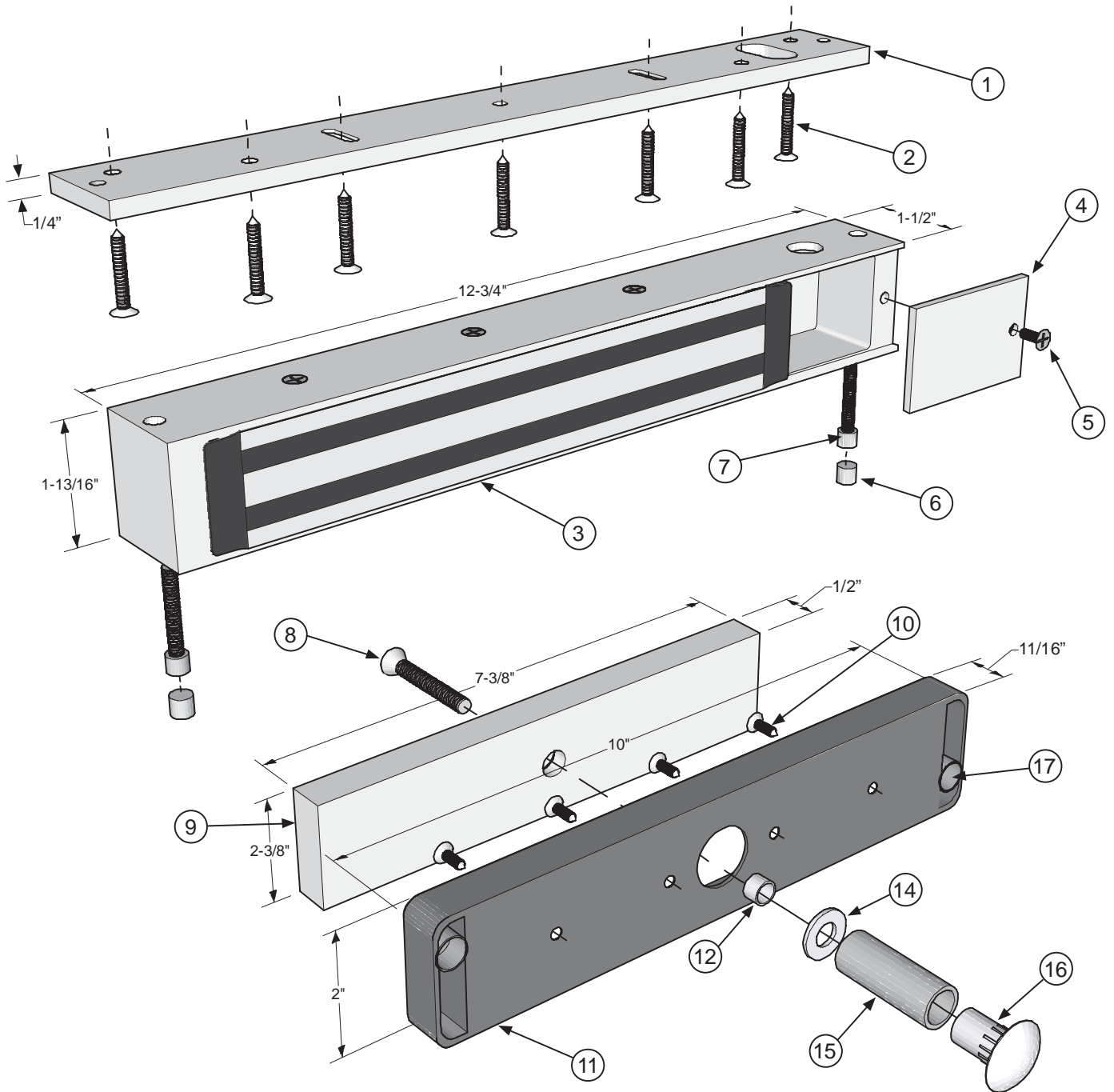

LEGEND ON
NEXT PAGE





705 Emmett Street • Bristol, CT 06010
 1-877-DynaLock • www.dynalock.com

MODEL 2280 SINGLE/OUTSWING ELECTROMAGNETIC LOCK

INSTALLATION INSTRUCTIONS

PARTS LEGEND

ITEM	DESCRIPTION	PART #
1	Baseplate	301264
2	#10x1" Self-Tapping Screw	*
2	10-24x1/2" Machine Screw	*
3	Lock Housing	301297
4	Access Cover	301296
5	8-32x3/8" Machine Screw	300608
6	Anti-Tamper Plug	*
7	1/4-20x1-1/4" Socket Head Screw	300603
8	5/16-18x2" Arm. Screw, Turned	*
9	Armature	300968

ITEM	DESCRIPTION	PART #
10	#8x1" Self-Tapping Screw	*
10	8-32x3/8" Machine Screw	*
11	Armature Housing	301245
12	0.360"L Armature Spacer	*
14	Steel Washer	*
15	Door Spacer Tube	*
16	Sex Nut	*
17	Disc Magnet (DSM only)	301289

* Part of Hardware Kit (301304)

Refer to Page 6 for parts locations.



705 Emmett Street • Bristol, CT 06010
1-877-DynaLock • www.dynalock.com

MODEL 2280 SINGLE/OUTSWING ELECTROMAGNETIC LOCK

INSTALLATION INSTRUCTIONS

**PLEASE DELIVER THIS MANUAL
TO THE END-USER UPON COMPLETION
OF THE INSTALLATION**

THE FOLLOWING LISTINGS ARE PENDING



**NYC Mea #23-92-E
GWXT Auxiliary Lock**

FOR PRODUCT SUPPORT AND PARTS ORDERING INFORMATION CONTACT:

DynaLock Corp.
705 Emmett Street
Bristol, CT 06010
Bus: (877) DYNALOCK, Toll-Free USA
(860) 582-4761
Fax: (860) 585-0338

DYNALOCK ON THE INTERNET:

E-mail: info@dynalock.com
Website: www.dynalock.com