

1819 SERIES FIRE LABELED HEAVY-DUTY ELECTRIC STRIKE

Installation Instructions

- To determine if the Strike Shim positions need adjustment, measure dimension “R” (see Figure 1) from the center to the edge of the latch. When necessary rearrange Strike Shims according to the chart below. The “shipped as default” positions are illustrated in Figure 2.

Shim Placement Chart

Note: Shims consist of two thin and one thick. Install with the indicated hardware per the appropriate measurement R range.

Measurement “R”	“S1” Shims	“S1” Screws	“S2” Shims	“S2” Screws
5/16” (8.2mm) or Less	None	M4 x 10mm	1 thick, 2 thin	M4 x 10mm
5/16” - 3/8”, (8.2 - 9.7mm)	1 thin	M4 x 10mm	1 thick, 1 thin	M4 x 10mm
3/8” - 7/16”, (9.7 - 10.7mm)	1 thick	M4 x 10mm	2 thin	M4 x 10mm
7/16” - 1/2”, (10.7 - 12.2mm)	1 thick, 1 thin	M4 x 14mm	1 thin	M4 x 10mm
1/2” - 9/16” (12.2 - 13.7mm)	1 thick, 2 thin	M4 x 14mm	none	none

Shipped as Default

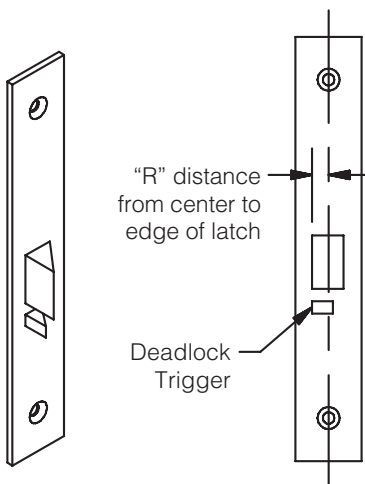

Mortise Lock

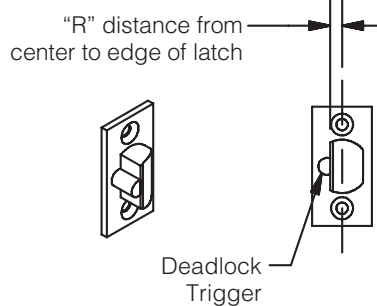

Cylindrical Lock

Figure #1

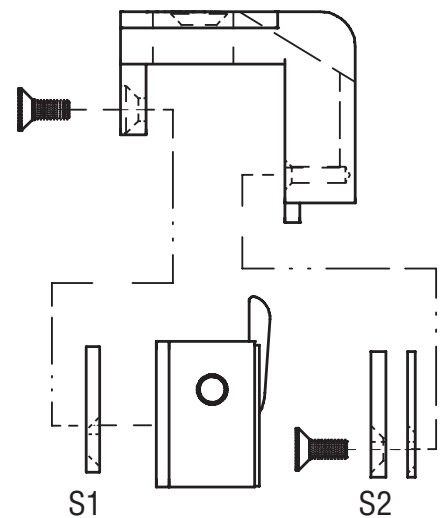

Figure #2

When installing an electric strike on an inactive door of a set of double doors, it can be treated the same as a frame installation in most situations.

1819 SERIES Installation Instructions (Continued)

2. Determine the horizontal centerline.

FOR MORTISE LOCKS: Position the strike against the edge of the door with the deadlock trigger fully on the strike's angled ramp and the latch within the strike cavity. Move door close to the frame. The horizontal centerline is clearly molded into the strike's pry-guard. Transfer onto door frame.

FOR CYLINDRICAL LOCKS: Simply align the center of the latch with the center of the strike cavity. Move door close to the frame. The horizontal centerline is clearly molded into the strike's pry-guard. Transfer onto door frame.
3. Determine the vertical centerline of the door lock face, carefully considering any stops or gasket and transfer onto the door frame.
4. Use the vertical and horizontal centerlines marked on the drawing below to prepare the door frame for cutting.
5. If required, install the optional "no weld" mounting brackets as per the instructions included with the mounting brackets in the hardware pack.
6. Connect the incoming wiring from the power supply to the terminal screws on the strike insert. DynaLock door strikes are not polarity sensitive although be certain to observe proper polarity if a suppression diode is required for access control applications.
7. Install the door strike in the door frame using the screws provided.

1819

MEASUREMENT	FRACTIONAL INCHES	DECIMAL INCHES	METRIC mm
A	1-3/8"	1.38	34.9
B	9"	9.0	228.6
C	3-3/4"	3.75	95.3
D	1-1/2"	1.50	38.1
E	5/16"	0.31	7.8
F	5/32"	1.56	4.0
G	1-7/8"	1.88	47.6
X	Vertical Centre Line of Door Lock and Mounting Face Plate		
K	8-3/8"	8.38	213.0
M	12-24	N/A	N/A

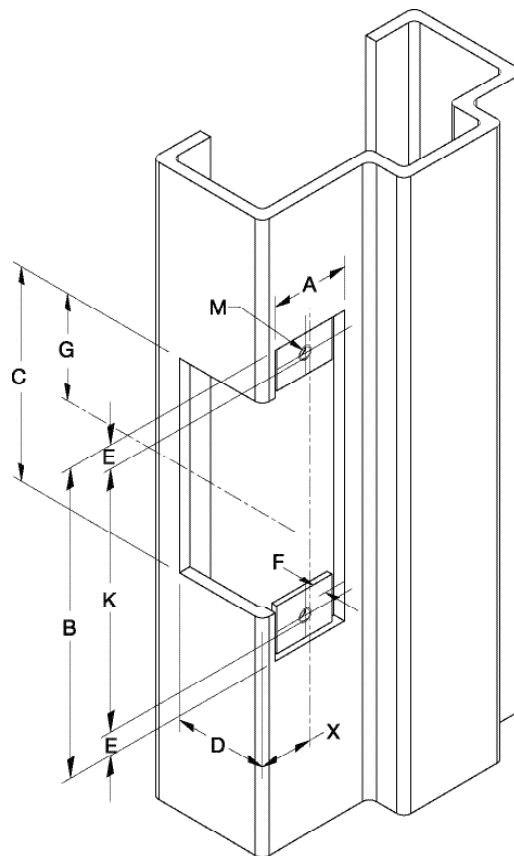

NOTE: Specifications subject to change without notice.

* Dimension F is measured from face of mounting tab to face of frame.