

Description

The 2806 Series is a flush wall mount door holder for use with single doors. It is UL and cUL Listed and FM approved.

Table 1. Specifications

Cat. No.	Voltage	Current Draw
2806	24V AC 60 Hz	0.015A
	24VDC	0.015A
	120V AC 60 Hz	0.015A

Installation

Install and wire in accordance with applicable codes, standards, such as NFPA publications 70 (National Electrical Code), 72 (National Fire Alarm Code) and 80 (Standard for Fire Doors and Fire Windows) and authorities having jurisdiction

- Using Figure 1 and Table 2, locate the intersection of Dimension X and Dimension Y. Dimension Z is shown at the intersection in the gray area.

NOTE: If dimension X or Y is not shown on the chart, extrapolate Dimension Z (i.e., if X=7 and Y=30, then Z = (27-5/8 - ((27-5/8 - 27-1/4)/2)) => Z=27-9/16"

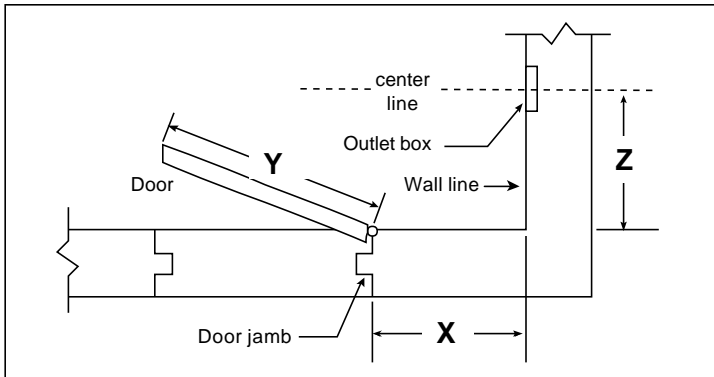

Figure 1. Locating the Door Holder

- Install a single gang outlet box (not supplied) on the horizontal center line and 5" from the top of the door.

NOTE: The outlet box must be able to withstand a maximum holding force of 50 pounds.

If X and Y intersect in the blank area in Table 1, DO NOT install the outlet box. The contact plate and electromagnet cannot be aligned with these dimensions.

Electromagnetic Assembly Mounting

⚠ WARNING

To prevent electrical shock, ensure power is disconnected.

- Refer to Figure 2. Pull field wiring through conduit into the single gang outlet box.
- Establish earth-ground continuity in accordance with applicable codes, standards and authorities having jurisdiction. A green insulated lead wire is provided for this purpose.
- Refer to Figure 3 and connect as instructed below:
 - 120V AC operation.** Connect field wiring to terminals marked "120V AC" and "COM".
 - 24V AC/DC operation.** Connect field wiring to terminals marked "24V AC/DC" and "COM".
- Secure the electromagnet bracket assembly to the outlet box using two #6-32 x 1/2" screws provided (Figure 2).
- Mount the cover to the electromagnetic bracket assembly and secure with two #6-32 x 3/8" screws provided (Figure 2).

NOTE: The combined projection of the electromagnet assembly and the armature assembly is 1-27/32".

Table 2. Dimension chart (in inches).

		Y = Dimension of door width										
		28	30	32	34	36	38	40	42	44	46	48
X = Dimension of door jamb to wall	2	26	28	29-7/8	32	34	36	38	40	42	43-7/8	45-5/8
	4	26	28	29-7/8	32	34	36	38	40	42	43-7/8	45-5/8
	6	25-5/8	27-5/8	29-5/8	31-3/4	33-3/4	35-3/4	37-3/4	39-3/4	41-3/4	43-5/8	45-3/8
	8	25-1/4	27-1/4	29-1/4	31-3/8	33-1/2	35-1/2	37-3/8	39-1/2	41-1/2	43-3/8	45-1/4
	10	24-5/8	26-3/4	28-3/4	30-7/8	33	35	37	39-1/8	41-1/8	43	44-7/8
	12	23-3/4	25-7/8	28	30-1/8	32-1/4	34-3/8	36-3/8	38-1/2	40-5/8	42-1/2	44-3/8
	14	23-3/4	25	27-1/4	29-3/8	31-1/2	33-3/4	35-7/8	38	40	42	43-7/8
	16	21-3/4	24	26-1/4	28-1/2	30-3/4	33	35-1/8	37-1/4	39-3/8	41-3/8	43-3/8
	18	20	22-1/2	25	27-3/8	29-3/4	32	34-1/4	36-1/2	38-5/8	40-5/8	42-1/2
	20	18-1/4	21	23-1/2	26	28-1/2	30-7/8	33-1/8	35-3/8	37-5/8	39-5/8	41-5/8
	22		18-3/4	21-5/8	24-3/8	27	29-3/8	31-3/4	34-1/8	36-1/2	38-5/8	40-3/4
	24				22-1/2	25-1/2	28-1/8	30-5/8	33-1/8	35-5/8	37-7/8	40
	26						26-1/4	29	31-5/8	34-1/4	36-1/2	38-5/8
	28								29-3/4	32-1/2	34-7/8	37-1/8
	30								27-3/4	30-5/8	33	35-3/8
	32										31-3/8	33-7/8

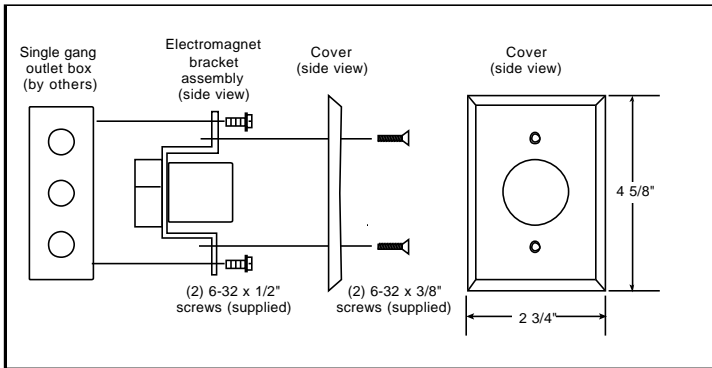

Figure 2. Mounting

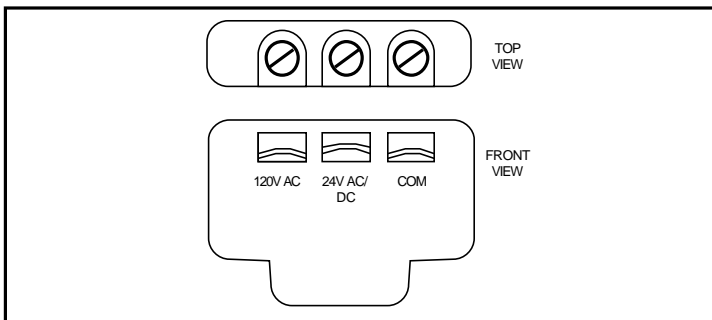

Figure 3. Terminal Block

Armature Assembly Mounting

NOTE: Armature assembly must be mounted vertically (Figure 4) to obtain correct alignment with the electromagnet.

- Using a 5/32" Allen wrench, turn the contact plate adjusting screw (Figures 5 and 6) counterclockwise to loosen the contact plate.
- Place the transfer marking points in the armature mounting holes (Figure 4).

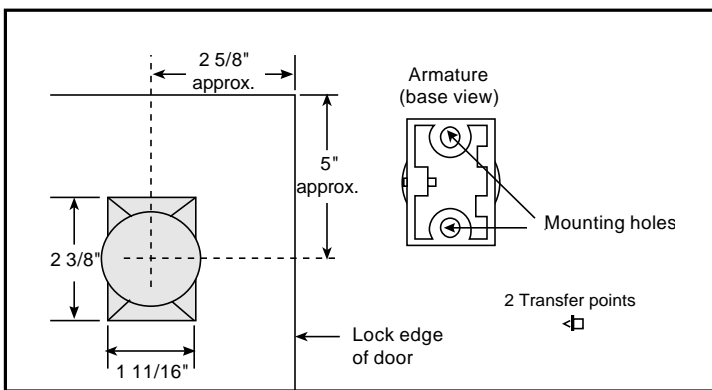

Figure 4. Mounting the Armature Assembly

- To locate the two mounting holes in the door, hold the contact plate centered against the magnet, open the door and press against the transfer marking points on the armature base. Release the door and remove the transfer marking points.
- Mount the armature base assembly using one of the following methods:
 - Thru-bolt mounting (Figure 5).** Center punch the two holes (at the points marked in step 3) and drill 5/16" diameter through the door. Distance between the center points should equal 1-3/4".

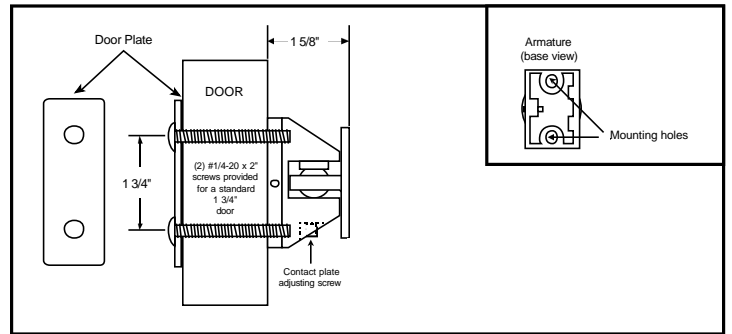

Figure 5. Thru-Bolt Mounting

NOTE: Thru-bolt mounting is recommended for standard 1-3/4" hollow metal, hollow core or composite type wood doors.

NOTE: For 2" doors use (2) 1/4-20 x 2" bolts.

Secure the armature assembly, with the contact plate adjusting screw facing down, to the door as shown in Figure 5 or 6, using (2) 1/4-20 x 2" screws (supplied).

- Surface concealed mounting (Figure 6).** Measure two points for 1/8" holes drilled 1/2" on center, equidistant from each marked point. Center punch the holes and drill 1/8" diameter x 1-1/4" deep. Install the concealed mounting plate using two #10 x 1-1/2" screws provided.

NOTE: Surface concealed mounting is not recommended for hollow metal, hollow core or composite wood type doors.

Align the holes for the concealed mounting plate in the armature base with the pins on the concealed mounting plate and secure the armature base to the door by tightening the set screw.

- Align the contact plate against the electromagnet. The contact plate **must be** centered and lie flat against the magnet to ensure sufficient holding force. Tighten the contact plate adjusting screw until the plate is firm but not set. **Do not overtighten the contact plate.**
- Recheck alignment and adjust if necessary.
- Adjust the door closer to exert 3 pounds of force when the door is open and armature and magnet are in contact.
- Energize the electromagnet and check operation.

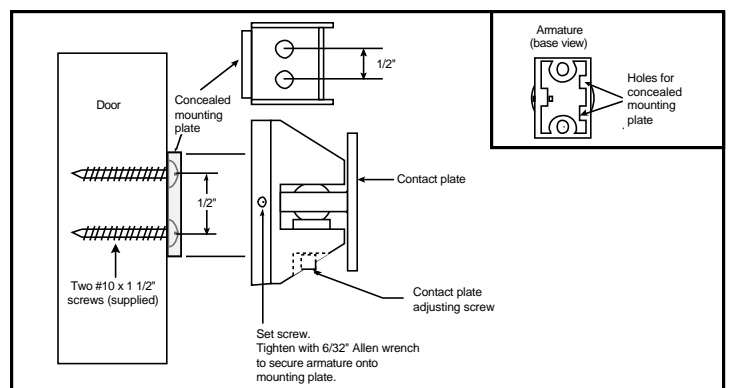

Figure 6. Surface Concealed Mounting