

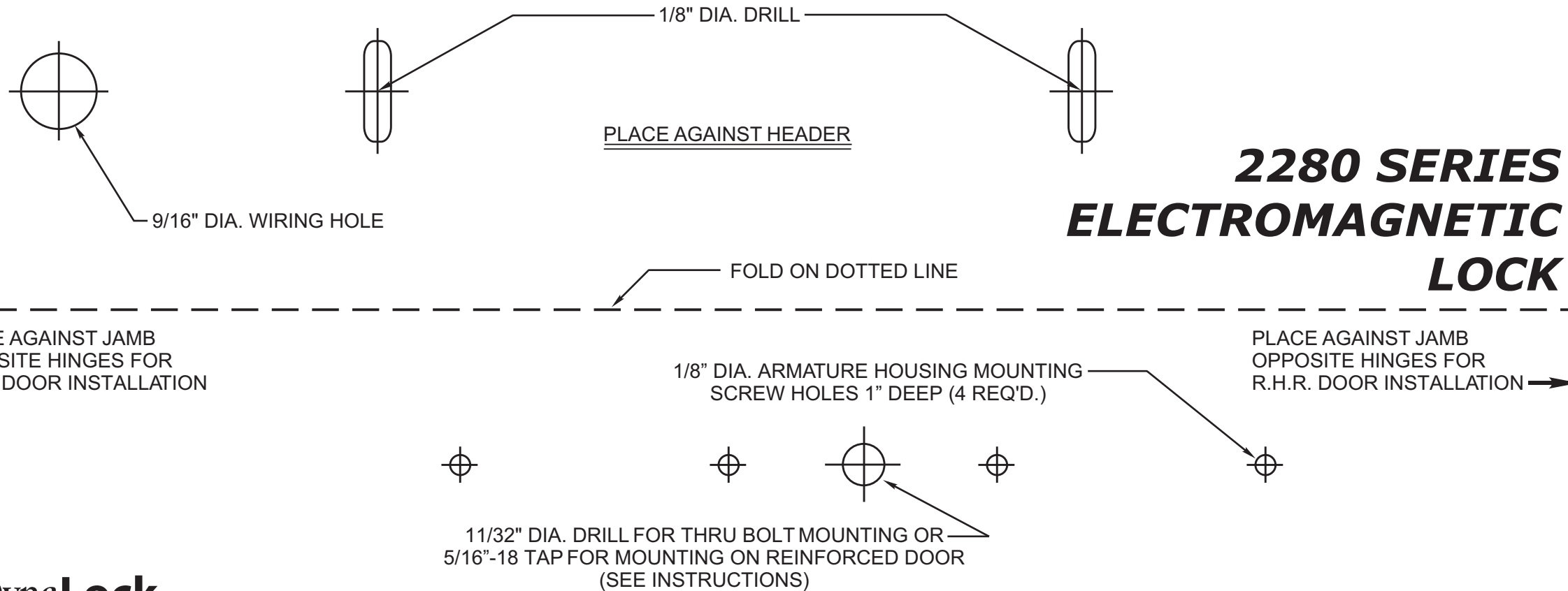

Emergency Tech Support is available Monday - Friday, 5:00PM-8:00PM (EST)

By Calling: Mike @ (860) 637-2394 or Glen @ (860) 637-2599

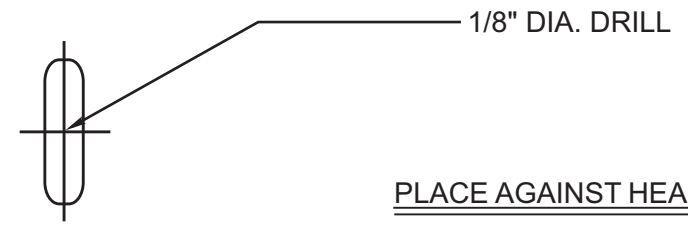



PLACE AGAINST HEADER

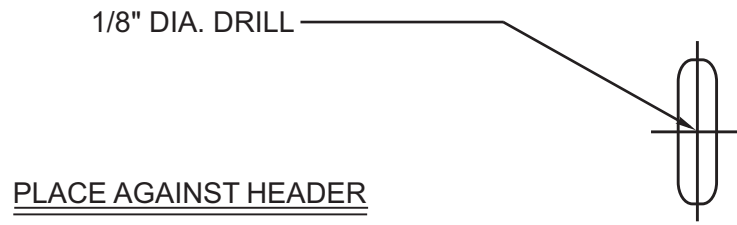
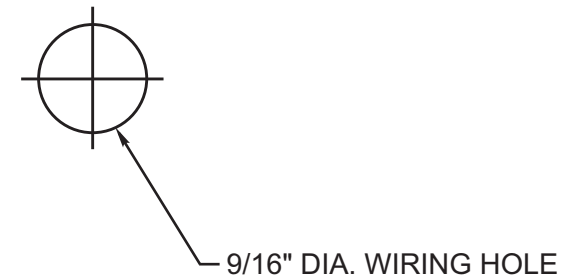
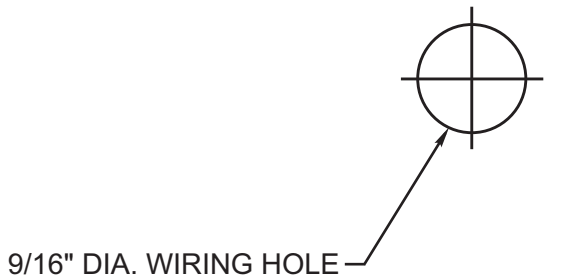

PLACE AGAINST HEADER

FOLD ON DOTTED LINE

FOLD ON DOTTED LINE

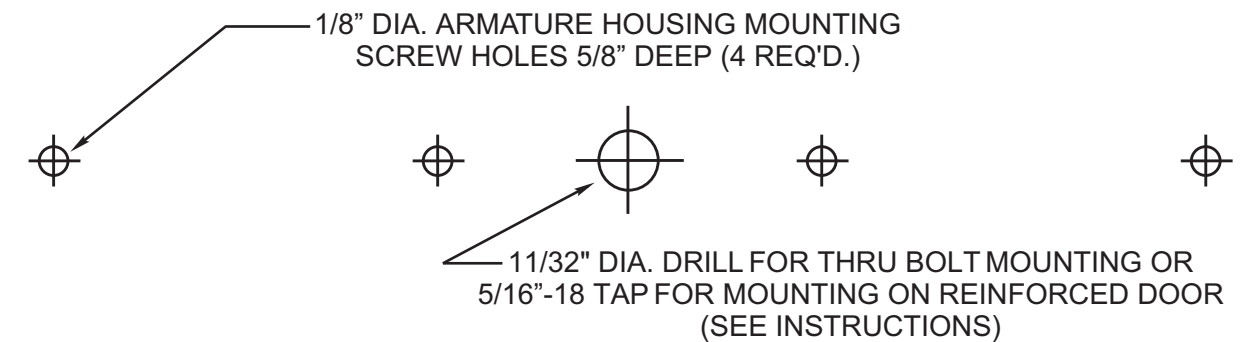

PLACE ON
CENTERLINE
OF DOOR
OPENING

2282 SERIES ELECTROMAGNETIC LOCK

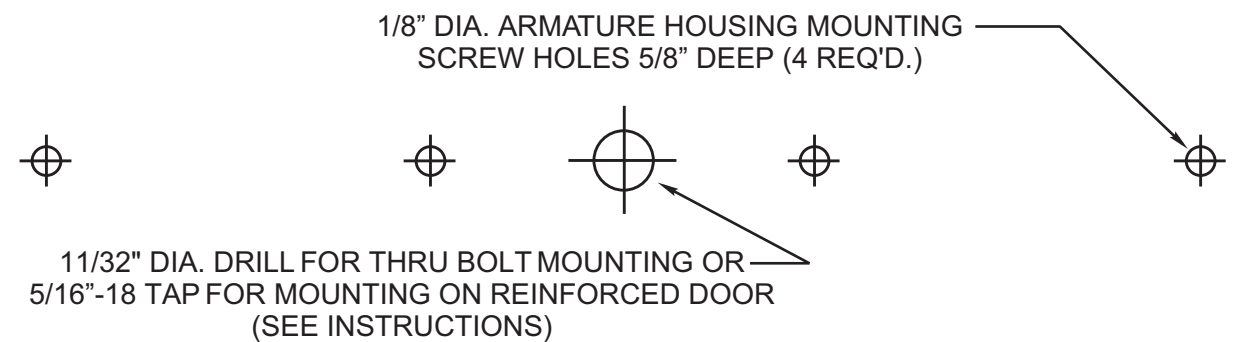

11/32" DIA. DRILL FOR THRU BOLT MOUNTING OR
5/16"-18 TAP FOR MOUNTING ON REINFORCED DOOR
(SEE INSTRUCTIONS)

LEFT HAND DOOR PREP

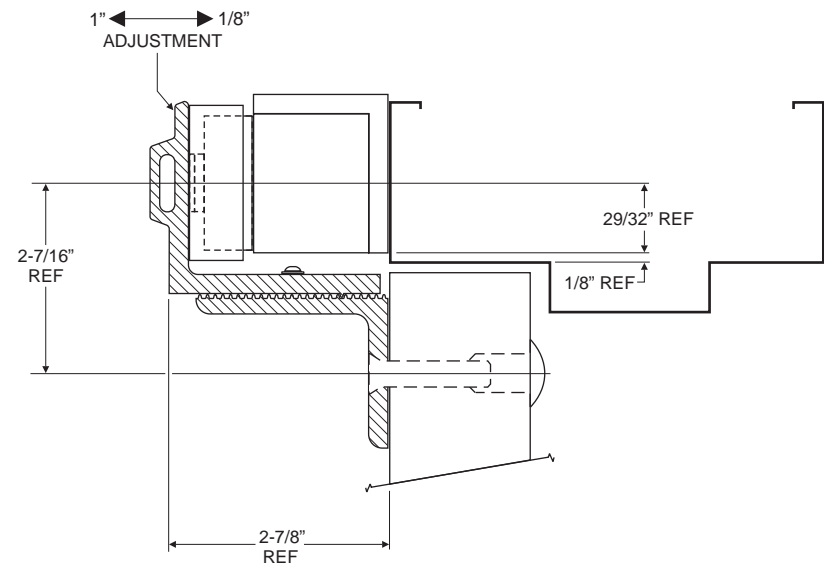

RIGHT HAND DOOR PREP

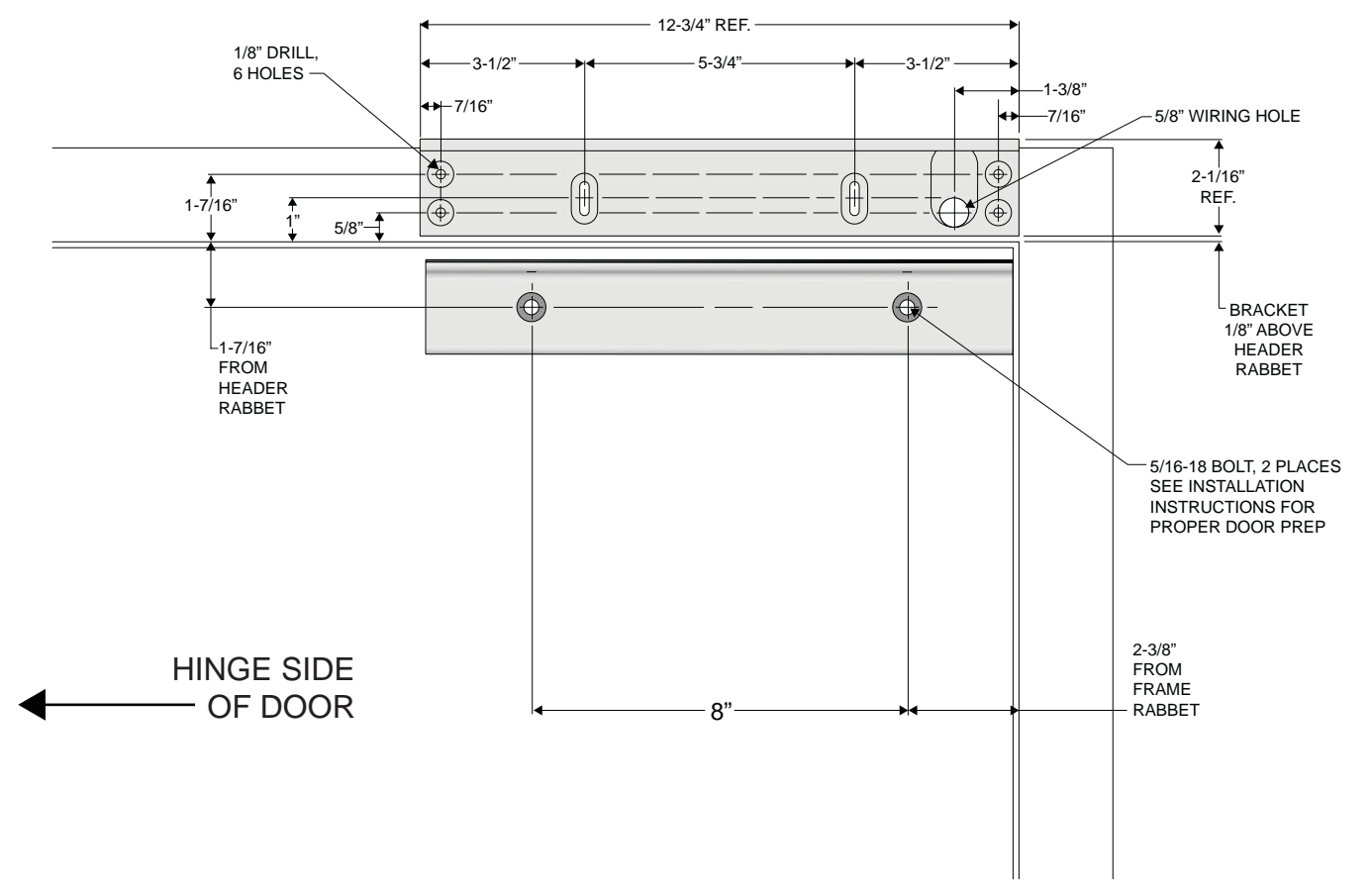
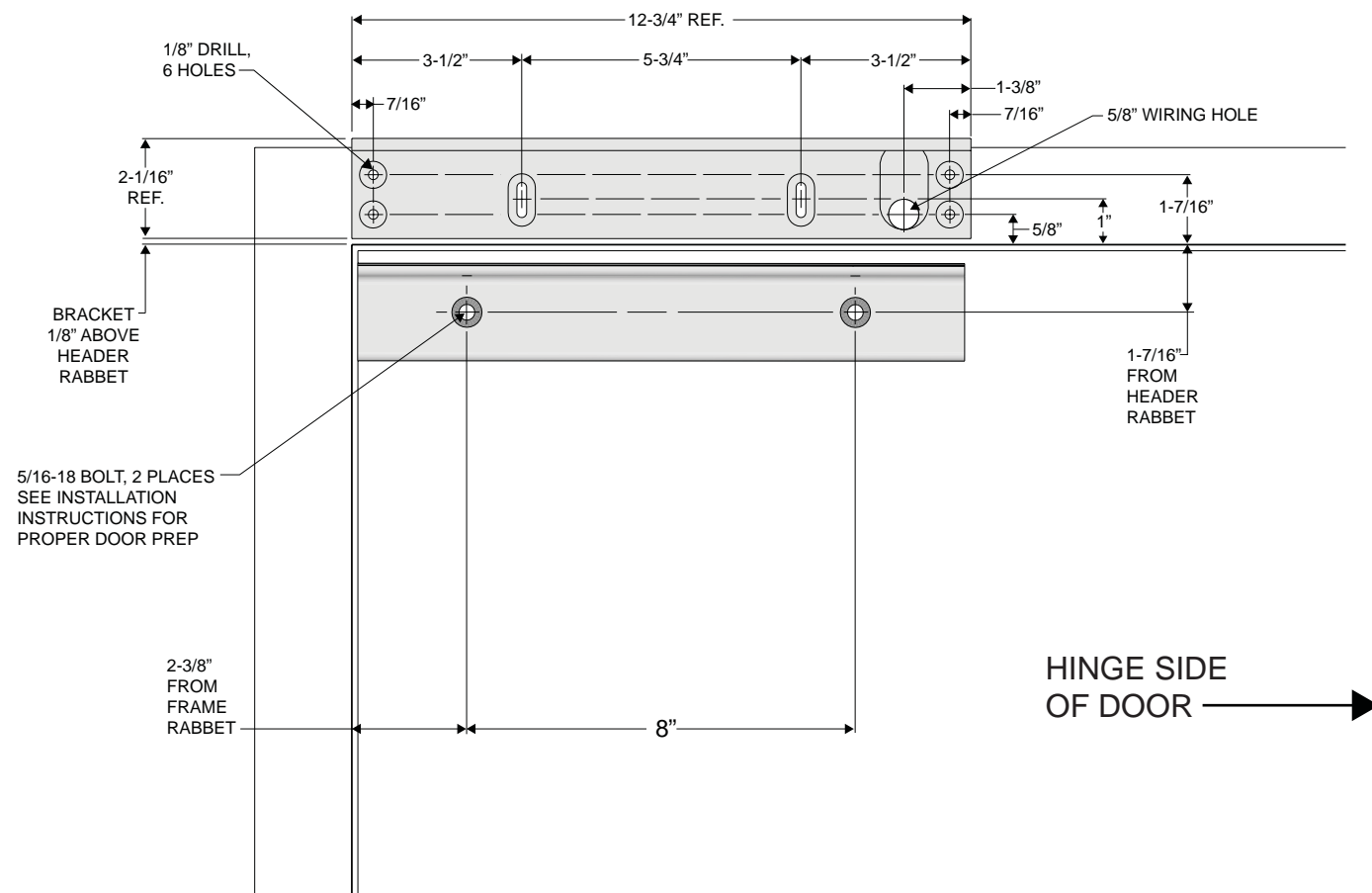
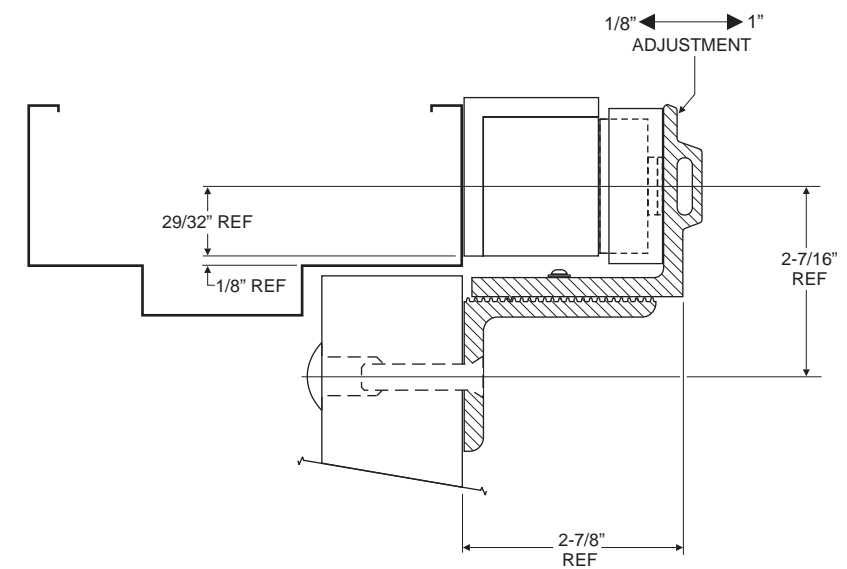

NOTE:
ABOVE INFORMATION IS FURNISHED TO IDENTIFY HOLE LOCATIONS. SEE INSTALLATION INSTRUCTIONS FOR DOOR AND FRAME PREPARATION.



DynaLock Corporation
705 Emmett Street • Bristol, CT 06010
Tel: (860) 582-4761 • Fax: (860) 585-0338

Template
Drawing

DRWN: MJL Date: 01/03/07
CHK'D: MJL Date: 01/03/07
APPV'D: JAS Date: 01/18/07

Title: 2280xTJ80 SINGLE INSWING MAGLOCK
TEMPLATE DRAWING

Page 1 Of 1 Scale: — Size: B Drawing #: 301302 REV:

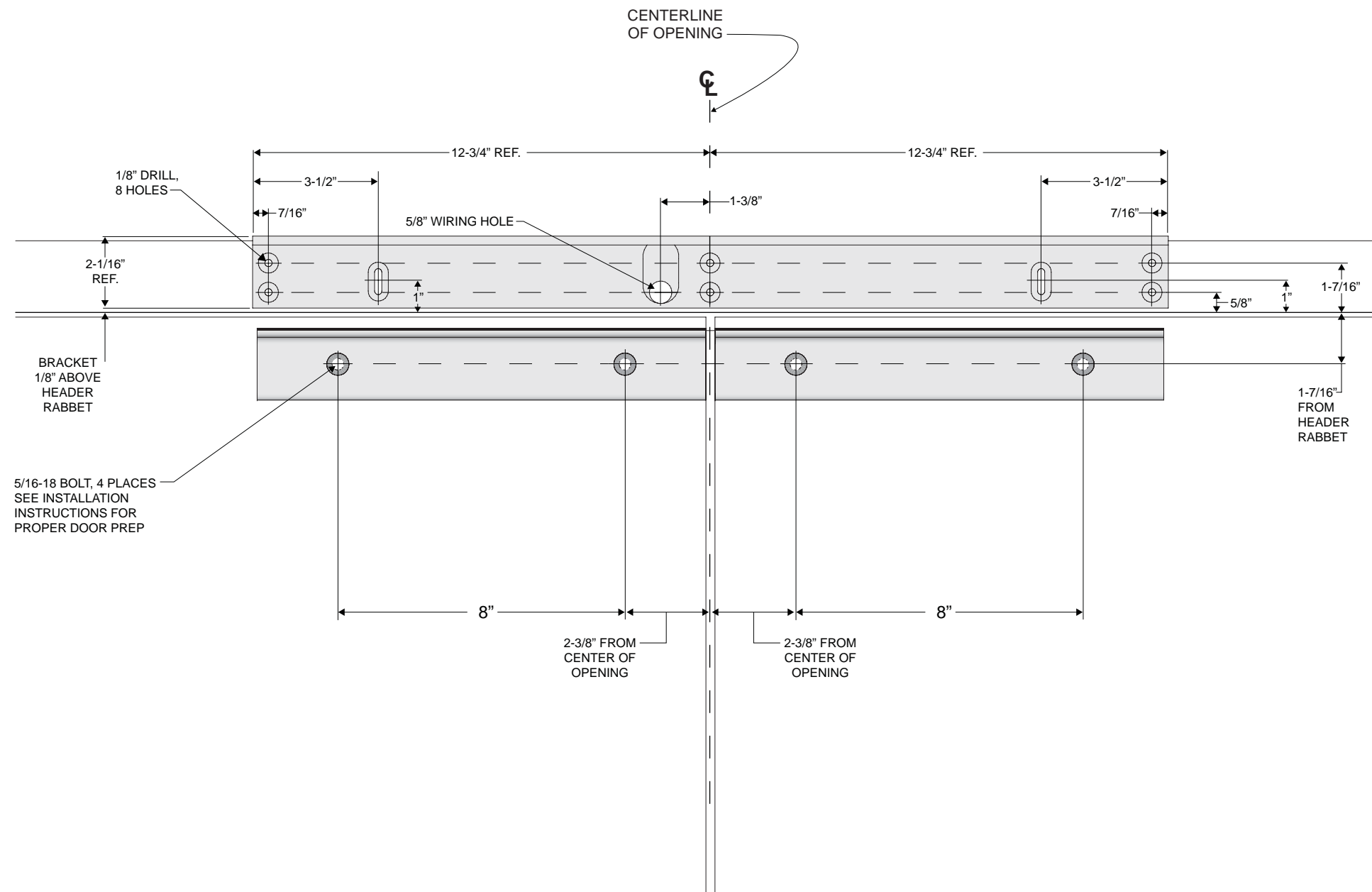
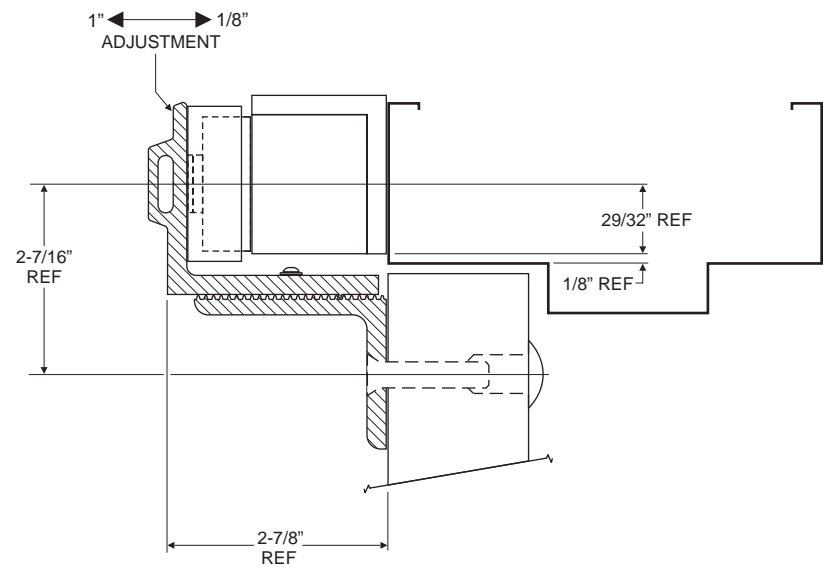

NOTE:
ABOVE INFORMATION IS FURNISHED TO IDENTIFY HOLE LOCATIONS. SEE INSTALLATION INSTRUCTIONS FOR DOOR AND FRAME PREPARATION.



DynaLock Corporation
705 Emmett Street • Bristol, CT 06010
Tel: (860) 582-4761 • Fax: (860) 585-0338

*Template
Drawing*

DRWN: MJL Date: 03/28/07
CHK'D: MJL Date: 03/28/07
CHK'D: Date:
APPV'D: JAS Date: 04/26/07

Title: 2282xTJ82 DOUBLE INSWING MAGLOCK
TEMPLATE DRAWING

Page 1 Of 1	Scale: —	Size: B	Drawing #: 301341	REV:
----------------	-------------	------------	----------------------	------